

DEVELOPMENT AND ASSESSMENT OF A CONTROL APPROACH FOR A LOWER-LIMB  
EXOSKELETON FOR USE IN GAIT REHABILITATION POST STROKE

By

Spencer Ambrose Murray

Dissertation

Submitted to the Faculty of the  
Graduate School of Vanderbilt University  
in partial fulfillment of the requirements  
for the degree of

DOCTOR OF PHILOSOPHY

In

Electrical Engineering

May, 2016

Nashville, Tennessee

Approved:

Michael Goldfarb, Ph.D.

Robert J. Webster III, Ph.D.

Nilanjan Sarkar, Ph.D.

Eric J. Barth, Ph.D.

Richard Alan Peters II, Ph.D.

To my wife, Meredith.  
For diligently caring for our punk dog during all the time I spent in Atlanta.

## ACKNOWLEDGEMENTS

This document presents the collection and summary of the work I have performed over the past five years. I consider myself lucky to have found both a project that is so well suited to my interests and a lab environment that is so well suited to my work style. I am also grateful for the opportunity my advisor, Dr. Michael Goldfarb, has given me. His philosophy on graduate-student management has provided me the freedom to experiment with numerous ideas in the pursuit of my research goals and led to some unique investigations. It is not clear to me that any other professor would have green-lighted a project with a description beginning “We’ll need a copy of the Rock Band videogame”. At the same time, his dedication and guidance in the development of the control approach presented in this dissertation were invaluable. The balance he struck as my advisor was perfect.

I would also like to thank the researchers who began this project before my time at the Vanderbilt Center for Intelligent Mechatronics. Their originality and foresight in the creation of the Vanderbilt Exoskeleton made the device extremely well suited to the research I would spend the following years conducting. In particular, I would like to thank Dr. Ryan Farris and Dr. Hugo Quintero for their efforts in design and control which produced the first prototypes of the exoskeleton. Their work is outstanding. My appreciation also goes out to Dr. Kevin H. Ha for his assistance. Dr. Ha contributed his own important research developments to the exoskeleton project while still finding time to help me with the legwork and heavy lifting necessary to carry out my preliminary studies at the Shepherd Center. Andres Martinez Guerra deserves recognition for his role in the collection and analysis of data used in one portion of an experiment which I was unable to conduct. The feedback, input, and advice I received from Clare Hartigan, Casey Kandilakis, and Elizabeth Sasso, the project’s talented physical therapists, was very valuable and guided the development of many aspects of the controller. I am thankful for the assistance I received from Don Truex and Dr. Skyler Dalley who both did a tremendous amount of work in creating the electronics and software used in the Indego exoskeleton, and who both went out of their way to assist me in porting my controller onto the Indego prior to my final experiments. Dr. Jason Mitchell also deserves recognition for

his role in the development of the exoskeletons, and for his flexibility in producing many things I used in my research over the years. I do not believe anyone could have engineered and machined a set of exoskeleton-brake-release devices as rapidly as Dr. Mitchell did. And thanks to the other members of the exoskeleton projects, Andrew Ekelem and Benjamin Gasser, for their help in numerous aspects of my research.

## TABLE OF CONTENTS

	Page
DEDICATION.....	ii
ACKNOWLEDGEMENTS.....	iii
LIST OF TABLES.....	vii
LIST OF FIGURES.....	viii
 Chapter	
<b>I. INTRODUCTION .....</b>	<b>1</b>
Cerebrovascular Accident.....	2
Post-Stroke Gait-Training Interventions.....	3
Robotic-Assisted Interventions and Associated Control Methodologies.....	5
Non-Trajectory-Based Control .....	8
<b>II. ACTIVE COMPENSATION FOR PASSIVE EXOSKELETON DYNAMICS .....</b>	<b>11</b>
<b>MANUSCRIPT I: ACTIVE COMPENSATION OF PASSIVE DYNAMICS OF A POWERED     LOWER-LIMB EXOSKELETON .....</b>	<b>12</b>
Abstract.....	12
Introduction.....	12
Methods and Results .....	20
Conclusion .....	22
ADDENDUM .....	22
<b>III. PHYSIOLOGICAL SIGNAL RESPONSE TO TASK ENGAGEMENT.....</b>	<b>23</b>
<b>MANUSCRIPT II: PHYSIOLOGICAL SIGNAL RESPONSE TO VARYING TASK     ENGAGEMENT IN A MULTI-LIMB COORDINATED MOTOR-LEARNING TASK.....</b>	<b>23</b>
Abstract.....	23
Introduction.....	24
Methods.....	25
Results.....	29
Discussion.....	32
Conclusion .....	33
ADDENDUM .....	33
<b>IV. NON-TRAJECTORY BASED CONTROLLER DEVELOPMENT AND PRELIMINARY STUDY .....</b>	<b>34</b>
<b>MANUSCRIPT III: DEVELOPMENT AND PRELIMINARY ASSESSMENT OF A NON-     TRAJECTORY BASED CONTROLLER FOR A POWERED LOWER-LIMB EXOSKELETON ....</b>	<b>35</b>
Abstract.....	35
Introduction.....	35
Controller to Facilitate Recovery following Stroke .....	39
Experimental Implementation and Preliminary Assessment .....	49
Single-Session Results .....	56

Conclusion .....	57
ADDENDUM .....	59
V. COMPARISON OF NON-TRAJECTORY BASED AND TRAJECTORY BASED CONTROL .....	60
MANUSCRIPT IV: A PRELIMINARY CROSSOVER STUDY COMPARING THE EFFICACY OF TRAJECTORY-BASED AND NON-TRAJECTORY BASED CONTROL IN A LOWER-LIMB EXOSKELETON.....	61
Abstract.....	61
Introduction.....	61
Controller Descriptions .....	64
The Non-Trajectory Based Controller .....	64
The Trajectory Based Controller.....	68
Methods.....	69
Results.....	76
Discussion .....	78
Conclusion .....	81
ADDENDUM .....	82
VI. CONCLUSION AND FUTURE WORK .....	85
REFERENCES .....	88

## LIST OF TABLES

Table		Page
1	Percent Change in EMG Magnitude for each Assistance Condition.....	20
2	Range of Motion Analysis for Exoskeleton.....	21
3	Results of Statistical Analysis.....	29
4	Baseline Characteristics of Stroke Subjects (2015).....	53
5	Tunable Control Parameters for each Subject.....	55
6	Baseline Characteristics of Stroke Subjects (2016).....	71
7	Therapy Condition Order for each Subject.....	71
8	Non-Trajectory Based Tunable Control Parameters for each Subject.....	74
9	Trajectory Based Controller Tunable Control Parameters for each Subject.....	75
10	Change in Gait Variables for each Session.....	78

## LIST OF FIGURES

Figure		Page
1.1	Simplified state machine used in gait-phase recognition.....	15
1.2	Trajectories from exoskeleton with gait phase divisions shown.....	16
1.3	Exoskeleton prototype and experimental setup.....	17
1.4	Graph of electromyogram results from rectus femoris.....	19
1.5	Effects of exoskeleton with and without ACPD on gait trajectories.....	21
2.1	Rock Band™ drum controller.....	26
2.2	Display from Rock Band™ videogame.....	27
2.3	Plots of physiological signals vs task load in experimental condition.,.....	30
2.4	Plots of physiological signals vs task load in control condition.....	31
3.1	Exoskeleton configuration in each controller state.....	41
3.2	Configuration parameters for assistive control approach.....	45
3.3	Finite state machine switching conditions of the assistive controller.....	48
3.4	Vanderbilt lower-limb exoskeleton.....	52
3.5	Subject using experimental controller with therapist assistance.....	53
3.6	Joint angles, torques, and powers from a subject using the controller.....	54
3.7	Bar graph of averaged single-session gains for each subject.....	57
3.8	Bar graph of averaged single-session gains across all subjects.....	57
4.1	Exoskeleton configuration in each controller state.....	64
4.2	Switching conditions for TB and NTB controllers.....	65
4.3	The Indego exoskeleton.....	69
4.4	A subject in the Indego with a therapist present.....	72
4.5	Single-session changes in gait-speed and stride length.....	76
4.6	Single-session changes in hip and knee excursion.....	77
4.7	Joint angles, torques, and powers produced both controllers.....	82



# CHAPTER I

## INTRODUCTION

The work reported here revolves primarily around the development of a novel control scheme for a lower-limb exoskeleton. The controller is described in full in the following pages which walk through the iterative development path that was followed in the controller's design and implementation. For reasons of clarity when discussing multiple control schemes, the novel control methodology detailed in this dissertation will be referred to as the non-trajectory-based controller (NTB controller). The remainder of the research presented was performed in order to evaluate the efficacy of the NTB controller in restoring gait functionality in subjects with gait impairment as the result of a stroke or cerebrovascular accident. The NTB controller is designed such that it could be implemented on any exoskeleton with backdrivable, independently-actuated (i.e. not kinematically linked) hip and knee joints. The Vanderbilt Exoskeleton (or Indego Exoskeleton) is particularly well suited to the application of this controller due to the system's highly backdrivable joints and lightweight nature. For these reasons, the NTB controller has (as of this writing) been implemented exclusively on these exoskeletons. A body of research has been compiled on the exoskeleton's functionality for spinal cord injured users [1-10], and without the work of Dr. Ryan Farris, Dr. Hugo Quintero, Dr. Kevin Ha, and Dr. Michael Goldfarb, this work would not be possible.

The field of rehabilitation robotics is one which has seen dramatic advancements in recent years, including the development of numerous robotic aids intended specifically for gait therapy. As such, it is necessary to clearly outline both the importance of robotically-assisted gait therapy and the novelty of the newly developed NTB controller. For that reason, the remaining sections of this chapter explore the impact of gait impairment as the result of stroke, as well as the numerous control methodologies of the existing gait-rehabilitation robots.

Chapters II through V of the document are comprised of the published works documenting the development of the NTB controller and the work done in evaluating the NTB controller's efficacy. These represent the original contributions of this dissertation. Chapter II describes preliminary work in reducing

the impact of the passive dynamics of a wearable exoskeleton on the user. The manuscript in the chapter was presented at the *2012 Annual International Conference of the IEEE Engineering in Medicine and Biology Society* (EMBC 2012). Chapter III presents work which analyzed the correlation of physiological signals with task engagement in a multi-limb coordinated motor-learning task. A version of the manuscript describing preliminary results was presented at the *2015 Annual International Conference of the IEEE Engineering in Medicine and Biology Society* (EMBC 2015). A version of the manuscript with the complete results is in preparation for publication. This latter, complete version is included in this document. Chapter IV presents a full description of the NTB controller and the results of a preliminary study to evaluate the efficacy of the controller in restoring gait functionality to users. This manuscript was published in the 3<sup>rd</sup> issue of the 24<sup>th</sup> volume of the *IEEE Transactions on Neural Systems and Rehabilitation Engineering*. Chapter V presents a crossover study which compared the efficacy of the NTB controller to the efficacy of both a trajectory-based controller and physical therapist assistance without an exoskeleton (i.e. conventional overground gait therapy). This last manuscript has been submitted for publication in the *IEEE Transactions on Neural Systems and Rehabilitation Engineering*. Chapter VI offers an analysis and summary of the contributed works. Where applicable, the chapters offer additional information not in the original manuscripts to offer context for their inclusion in this dissertation.

### Cerebrovascular Accident

Cerebrovascular accident (CVA) is the fourth leading cause of death in the United States, and also one of the leading causes of chronic disability, with an incidence of over 600,000 first-time strokes each year. Although present at higher rates (nearly 14%) in elderly populations, CVA is not a geriatric disease, with incidence as high as 0.5% in people under the age of 40, and 2.1% in those aged 40-59. Estimates from the American Heart Association suggest as many as 6.8 million Americans have incurred a CVA in their lifetime [11]. CVA occurs when a portion of the brain is permanently damaged due to either diminished blood flow (ischemic CVA) or a ruptured blood vessel in the brain (hemorrhagic CVA). The damage to the

brain results in a wide range of cognitive and motor impairments, but a frequent effect is hemiparesis, or partial paralysis of one side of the body. Hemiparesis affects 50% of the individuals who have incurred CVA. While facial and upper-limb paresis have their own implications for quality of life, lower-limb issues in particular leave over 150,000 people annually unable to walk unassisted [11], with many more requiring gait therapy to restore the ability to walk. Loss or impairment of gait functionality has the immediate impact of reducing a person's independence by limiting their ability to perform activities of daily living (ADLs). Other effects are less direct but affect quality of life nonetheless. Slower walking speeds have been linked with reduced physical activity [12]; an increased risk factor for recurrent stroke [11]; and reduced social activity, which increases the likelihood of post stroke depression [13]. Gait speed is also commonly used to estimate a subject's ability to ambulate within the household or within the community and as such is used as a measure of functional improvements in gait during the rehabilitation process [14]. With these factors in mind, gait improvements are a high priority for both physical therapists and CVA patients, ranking first in patient-reported rehabilitation goals [15]. Unfortunately, in spite of awareness that CVA rehabilitation is a high priority, the number of patients receiving outpatient therapy after CVA is estimated to be lower than prescribed [11], suggesting not all who need care receive it. Additionally, there is no single therapeutic intervention which is agreed upon as the most effective form of gait rehabilitation. Indeed, as discussed below, the deeply-heterogeneous nature of stroke impairment has led not only to a large number of disparate interventions, but to a large number of disparate efficacy measures as well.

### Post-Stroke Gait-Training Interventions

Gait therapy interventions have historically been motivated by the knowledge that there is a large increase in neuroplasticity in the period following brain injury (including CVA). There is evidence of neural sprouting [16], synaptogenesis (formation of new synapses between neurons) [16], dendritic branching [17], and reorganization of existing motor-neuron axons [18] occurring immediately after injury. During this period, the brain can form new connections that can help restore some portion of lost functionality. The

philosophy of how to best stimulate this plasticity has sometimes been summarized as “who wants to regain walking has to walk” [19], or simply, practicing walking is important when relearning to walk. Therefore, it has long been the goal of physical therapists (PTs) to have patients practicing walking as soon as possible after CVA in order to take advantage of any acute brain plasticity. This consists of conventional interventions like lower-limb strength training, balance exercises, and PT-assisted overground gait. Conventional therapy (CT) like this is advantageous as it relies only minimally on equipment but, depending on the therapy, may be physically strenuous and/or non-ergonomic for PTs. Overground gait training typically consists of a single patient attempting to walk while one PT helps the patient maintain balance, and a second PT crouches or kneels to help provide stance-knee stability and proper foot clearance in swing. The therapy thus requires multiple PTs per patient, and is physically taxing for the therapists, typically resulting in shorter session durations and fewer gait-cycle repetitions per session. Despite these shortcomings, there is evidence to suggest that CT of this type provides functional improvements in patients recovering from CVA [20-22]. Further, some studies have reported a reduced number of falls and lower incidence of faintness or dizziness in patients who participated in at-home strength and balance training exercises, relative to patients who participated in body-weight-supported treadmill training (discussed below) [23]. The same study reported an equal recovery of balance and walking ability in subjects, regardless of intervention style, suggesting that CT had significant benefits relative to body-weight-supported treadmill training. Positive results like these, coupled with the relatively small equipment requirements, make CT a popular approach to gait rehabilitation.

Despite its popularity, CT is not well suited for some situations. In order to best leverage acute brain plasticity, patients should begin practicing gait as soon as possible after CVA. Despite this, many patients remain nonambulatory for days or weeks after the stroke. Body-weight-supported treadmill training (BWSTT) enables many patients to begin walking earlier by supporting a fraction of their mass via an overhead harness. With an effectively reduced mass, patients are able to practice walking before they are able to support their own weight. Further, the intervention is somewhat less demanding for PTs. Although typically still requiring two to three therapists per patient, the weight reduction and balance assistance

provided by the overhead harness allows the PTs to focus on lower-limb kinematics. Because of this, more gait-cycle repetitions may be performed in a single BWSTT session than in a CT session of equivalent length.

BWSTT systems started emerging in the mid-nineties, when several studies demonstrated some efficacy in restoring walking ability to nonambulatory patients, and have remained in use for the last two decades [24-27]. It is also worth mentioning that split-belt treadmill systems, which require a patient to walk at different speeds with each leg, have been shown to improve step-length symmetry in patients walking with or without body-weight support [28-30]. More recently, BWSTT has been linked to an increased number of falls [23], and in a large-scale randomized clinical trial, has not been shown to produce improved functional outcomes relative to conventional overground training [31]. The increased incidence of falls is unsurprising. It has been established that patients who receive walking training without balance training are at a higher risk for falls than those who practice balance in addition to walking [32]. While the overhead harness in BWSTT alleviates a patient's load, it also creates an artificial stabilizing force which removes the burden of maintaining balance from the patient, potentially hampering their balance recovery. In spite of these shortcomings, the ability to offer patients recovering from CVA the chance to practice gait before regaining ambulatory capability has kept BWSTT a relevant and popular intervention option.

### Robotic-Assisted Interventions and Associated Control Methodologies

In addition to CT and BWSTT, recent technological advancements have enabled the development of robotic-assisted gait training (RAGT) systems, which began to emerge around the year 2000. RAGT systems are advantageous in that they reduce the need for PT assistance. Where BWSTT can require up to three PTs to assist with limb movement and system operation, RAGT typically removes PTs from a patient-assistive role and places them in a supervisory position, requiring only one therapist to monitor the session. Although the control methodologies vary considerably, the state-of-the-art systems nearly all rely on

trajectory-based control to guide a user's limbs through a kinematic path. The differentiating components of each control strategy are discussed.

The Hocoma Lokomat is perhaps the most popular RAGT system with over 600 installed units in operation [33]. The device attaches to the user's waist and lower limbs and supports them via actuated attachment points. The Lokomat operates by driving a patient's lower limbs through preset trajectories using high-gain position control as the user walks on a treadmill [34, 35]. This control method assures kinematically-correct strides with high step repetition. Later versions of the device also include variable assistance to require the user to exert effort to accomplish gait-related goals while still assisting the patient in achieving near-healthy gait kinematics [33]. The specifics of this variable-assistance method are unpublished as the device is a commercial product. A similar device, the Reha Stim Gait Trainer (GT), has also seen some commercial success. The GT provides end-effector trajectory control (i.e. footpath control) coupled with functional electrical stimulation (FES) [36]. By guiding the foot along a predefined trajectory, the system is able to achieve healthy gait kinematics with high repetition.

Other devices have expanded upon the trajectory based controllers of the Lokomat and Reha Stim GT. The Ambulation-Assisting Robotic Tool for Human Rehabilitation (ARTHUR) robot has been implemented with a control methodology which is manipulated manually to record a subject-specific trajectory which is then replayed, making the trajectory highly-customized to a user's individual needs [37]. The Lower-Extremity Powered Exoskeleton (LOPES) system relies on model-based methods to predict which portions of the gait cycle will require the most assistance. This permits the robot to increase assistance levels during portions of the trajectory where the user is expected to need the most help, and reduce assistance when it is unneeded [38, 39]. Finally, the Active Leg Exoskeleton (ALEX) produces force-field-based control methods which guide the user along desired trajectories using virtual walls around a pre-selected footpath [40, 41]. This permits the user to navigate the desired trajectory, only providing assistance when a significant deviation from the path is detected. Similar control methods used in the ALEX have also been shown to potentially reduce the metabolic cost of transport in healthy subjects [42].

All of the above-mentioned RAGT systems are stationary devices which incorporate body-weight support for subjects. In the last few years, overground exoskeleton systems have begun to emerge, although primarily for use in users with paraplegia [1, 10, 43]. The Hybrid Assistive Limb (HAL) uses a trajectory-based control methodology (named the autonomous control mode), not unlike the Lokomat, but with the advantages of permitting the subject to practice overground (as opposed to treadmill) gait. For those users with the ability to control some of the musculature of the lower-limbs, the HAL is equipped with a second control mode (the voluntary control mode) which uses electromyogram (EMG) recordings from the user's muscles as an input to the exoskeleton to determine when motion is desired. The HAL has been tested with patients recovering from CVA. The results were somewhat mixed, but suggested that users in the acute stages of recovery may increase their functional ambulatory category (FAC) scores [44-46]. Lastly, the H2 Exoskeleton is an overground exoskeleton which operates on the same basic principles as the ALEX exoskeleton. The H2 generates force-tunnel pathways around the prescribed kinematic trajectory and offers assistance only when the user deviates from this path [47].

It should be noted that the HAL exoskeleton with the "voluntary control method" is the single control methodology which does not make use of trajectory control. Instead, the device operates by using EMG signals from the user's muscles to decide when joint flexion or extension should occur. The device is also equipped with a second control option named the "autonomous control method" [38] which is trajectory based for subjects unable to provide sufficient EMG strength or coordination. Because EMG patterns in the lower-limbs can be altered dramatically as the result of CVA [51-53], it remains unclear what portion of the population EMG-based control may be effective for. In fact, researchers have continued to develop other control methods for the HAL which lack an EMG basis and opt instead for trajectory based control which mirrors the behavior of the unimpaired limb [54].

Despite the large body of literature available on the numerous RAGT systems, their efficacy is still debated. Some large-scale randomized controlled trials have produced results which suggest that 1.) overground gait training produces greater functional outcomes in spinal cord injured patients than do BWSTT or RAGT therapy using the Lokomat or Reha Care GT [31]; 2.) that BWSTT with PT assistance

produced greater gains in speed and impaired-limb single-support stance time than did training in the Lokomat [48]; and that 3.) CT produced greater gains in gait speed and walking distance than did an equivalent dosing of training in the Lokomat [49]. It should be noted, however, that these studies were performed with only two of the numerous RAGT systems which have been developed, and that even the evaluated systems have since developed upgrades to their control strategies, potentially increasing their efficacy (e.g., the Lokomat variable assistance feature discussed above). Moreover, although these articles present valid and important findings, other studies report contradictory results. One blinded randomized controlled trial of 155 non-ambulatory subjects suggested that a combination of PT assisted physiotherapy and training on the Reha Care GT I significantly increased the likelihood of a non-ambulatory subject regaining the ability to walk independently relative to an equivalent dosing of PT assisted physiotherapy alone [50]. A similar randomized controlled trial performed with 67 patients recovering from CVA was performed which suggested the Lokomat, when combined with PT assisted physiotherapy, produced larger gains in FAC scores and the ability to walk independently than did an equivalent dosing of physiotherapy alone [51]. Furthermore, numerous newer devices have undergone small-scale preliminary studies which lack the power of the randomized controlled trials reported above. A recent meta-analysis of articles from the Cochrane database suggests that when analyzed as a group, robotically assisted therapy combined with traditional physiotherapy produces an increased likelihood of a patient regaining the ability to walk independently [52]. In short, although conflicting reports exist, the literature supports the hypothesis that robotically assisted gait training shows promise as a method of improving gait-therapy intervention outcomes. Or, to echo the equine-themed synopsis of Dobkin et al. [31], the current body of literature does not support the belief that RAGT systems are ready to be put out to pasture.

### Non-Trajectory-Based Control

As mentioned above, the existing control methodologies for the state-of-the-art RAGT systems are predominantly trajectory based. The prevalence of trajectory-based control appears to be motivated by two



factors. First, meta-analysis of randomized control trials of various rehabilitation methods has demonstrated that task-oriented therapy - therapy in which the task to be improved (e.g., gait) is practiced - promotes improved functional outcomes in patients with CVA. Such studies suggest that high-intensity, repetitive, task-oriented gait training produces greater outcomes in balance, gait, and paretic limb strength [53, 54]. Trajectory-based systems are extremely good at producing repetitive, highly-consistent strides as the basis of trajectory control is the coordination of robotic (and therefore patient) kinematics. But is trajectory training truly task-oriented? While a subject's limbs are moved through healthy gait-cycle trajectories, it is not clear that the patient is required to coordinate or navigate the trajectories themselves, and it has been established that passive participation in therapy does not illicit the same plasticity that voluntary participation does [55]. For example, the presence of "Augmented Performance Feedback," which is designed to promote patient effort in newer Lokomat models [33], suggests that motivating a patient to actively participate in the therapy requires encouragement. Further, artificial balance assistance offered by the robotic attachment points, end effectors, and/or body-weight-support harnesses make it unnecessary (or at the very least, significantly easier) for the user to maintain his or her own balance. This reduces the similarity between the RAGT therapy and actual overground gait, somewhat eroding the task-oriented nature of the therapy. The HAL and H2 exoskeleton are not integrated with body-weight-support, so this latter point is not applicable to those systems.

Second, prior to the advent of RAGT systems, animal models had suggested that even in cases of complete spinal transection, treadmill training could generate some stepping behavior in the hind limbs of mammals, apparently caused by locomotor pattern generation in the portion of the spinal cord posterior to the injury [56, 57]. It was theorized that this recovery of locomotor function was due to spinal neuron plasticity. These findings suggested that externally-induced stepping (e.g., stepping motions elicited by a RAGT system) in the paretic limbs could induce some motor recovery, suggesting that a trajectory-based system could potentially promote this reorganization. However, further studies suggested that while similar spinal-neuron reorganization does occur in humans, even subjects who can produce stepping on a treadmill with body-weight support are incapable of sustaining overground gait [58]. Further, as CVA is a

fundamentally different form of neural impairment than SCI, the link is tenuous between such spinal-neuron plasticity and improved functional outcomes in patients with gait impairment resulting from hemiparesis. Nonetheless, the same interventions (e.g., Lokomat therapy) used in treating patients with SCI are regularly applied to patients recovering from CVA.

A control strategy which avoids trajectory-based control methods is capable of offering numerous potential advantages over the current state-of-the-art, trajectory-controlled RAGT systems. First, because the user is free to alter the trajectory of the gait cycle, he or she is capable of rapid alterations in gait to help maintain balance. This feature is of particular importance in overground exoskeletons, where PT guidance is the primary source of balance assistance, and a user is encouraged to practice balance during gait. Second, a non-trajectory based controller can accommodate step lengths, joint excursions, and step durations which may vary considerably on a step-to-step basis, as is common in subjects with hemiparesis (and healthy subjects, too, to a lesser extent). This is in contrast to trajectory-based controllers which strive to produce similar steps from cycle to cycle. Third, a non-trajectory based controller can require the patient to coordinate the movement of the lower limb during gait. Where trajectory-based systems may specify a kinematically healthy gait profile, a non-trajectory based controller can assist the user in specific goals (e.g., increased ground clearance) while still allowing the user to employ imperfect hip- and knee-joint profiles.

The non-trajectory based controller (NTB controller), which is the subject of this dissertation, was developed with the objective of providing these capabilities. In addition to requiring the patient to provide the spatiotemporal coordination of the lower limb, permitting rapid adaptation of the footpath, and allowing for significant step-to-step deviations in gait parameters, the NTB controller operates by providing assistive torques which encourage increased joint excursion, increased stability in the stance limb, and an effectively reduced limb-mass in the impaired limb. This is achieved via three individual assistive components which can be adjusted to tailor the assistive torques to a specific patient's needs. The NTB controller has undergone two small pilot studies which indicate that the controller is capable of substantially improving a patient's gait parameters after participating in gait training in an exoskeleton. The NTB controller is discussed at length in Chapter IV.

## CHAPTER II

### ACTIVE COMPENSATION FOR PASSIVE EXOSKELETON DYNAMICS

Preliminary work began with a study on actively reducing the passive dynamics of the exoskeleton and ensuring accurate phase detection in the user's gait cycle. The exoskeleton used in this preliminary work was a prototype of the Indego exoskeleton referred to as the Vanderbilt Exoskeleton. Because the targeted population for the NTB controller consists of patients with gait impairment as the result of CVA, adding 12 kg (26 lbs) of mass as well as joint friction and motor inertia (multiplied by a transmission ratio) has the potential to further impede the user's ability to walk. For this reason, it was necessary to demonstrate that by actively compensating for mass, motor inertia, and joint damping, the system could effectively reduce its own passive dynamic contributions, thereby minimizing the exoskeleton's passive effects on a patient. Following this work it would be possible to add assistive components to the controller's function with the assurance that the device as a whole would operate as an assistive - rather than resistive - gait trainer. In order to achieve this, active compensation for the exoskeleton's thigh-link mass (termed gravity compensation) was applied at the hip joint while compensation for damping and inertia effects was applied at the knee joints. Mass of the shank-link (approximately 0.5 kg, or 1 lbs) was not great enough to necessitate compensation at the knee, and motor inertia and damping were negligible compared to the force required to lift the weight of the thigh link against gravity. As such, gravity compensation at the knee joint was ignored, as were inertia and damping considerations at the hip. Manuscript I, presented below, develops the method of control for active compensation of the device's passive dynamics. A small trial demonstrated the ability of the compensation algorithms to reduce the exoskeleton's impact on the wearer. This manuscript was presented at the *2012 Annual International Conference of the IEEE Engineering in Medicine and Biology Society* (EMBC 2012).

# MANUSCRIPT I: ACTIVE COMPENSATION OF PASSIVE DYNAMICS OF A POWERED LOWER-LIMB EXOSKELETON

## Abstract

The authors intend to utilize a lower limb exoskeleton for gait assistance in individuals with lower limb neuromuscular deficit. The authors suggest that two foundational elements are required to do so effectively. First, the exoskeleton system must be capable of reliable real-time gait phase detection, in order to determine the nature of gait assistance to provide. Second, in gait phases or circumstances in which the exoskeleton provides minimal assistance, the passive dynamics of the exoskeleton should not hinder the individual (i.e., should have the capability to minimally interfere with gait dynamics). As such, the exoskeleton system should be capable of actively compensating for its passive dynamics, namely the inertial, gravitational, and frictional effects it imposes on the user. This paper describes the implementation of these two foundational elements (real-time gait phase detection and active cancellation of passive dynamics) on a prototype lower limb exoskeleton, and provides experimental data demonstrating their respective efficacy.

## Introduction

A number of neuromuscular impairments result in acute and/or chronic locomotor deficits. Common conditions resulting in gait deficit or impairment include incomplete spinal cord injury (SCI), cerebral palsy (CP), multiple sclerosis (MS), and complications resulting from cerebral vascular accident (stroke). There are approximately 260,000 persons in the US with SCI, approximately one half of which are incomplete injuries [59]; there are approximately 765,000 individuals in the US with CP [60]; and there are approximately 350,000 individuals in the US with MS [61]. Collectively, there are approximately 1.3 million persons in the US living with one of these conditions. Further, there are approximately 7 million

persons living in the US who have experienced a cerebral vascular accident (stroke) [59], and a significant portion of these have or have had gait impairment as a result.

The authors are developing a lower limb exoskeleton for gait assistance in individuals with lower limb neuromuscular deficit, such as individuals in those populations previously cited. In order to use a lower limb exoskeleton for these purposes, two foundational capabilities must exist. First, such a system must correctly and accurately detect the phase of the user's gait, so that it can cooperatively assist the user in an appropriate manner. Second, in order for a device to be useful as an assistive device for persons with lower limb deficit, it must not significantly impair the natural gait of the user in phases of gait, or in locomotion circumstances, in which the user needs minimal assistance from the device. Given the current state of robotic technology, implementation of a device capable of biological levels of torque and speed in the lower limb will likely introduce non-negligible mass, rotational inertia, and possibly joint friction. As such, the authors have designed and implemented a controller with active compensation for the purpose of mitigating these passive dynamics. This paper describes the implementation of these two foundational capabilities in a lower limb exoskeleton, and evaluates the efficacy of the gait phase detection (GPD) component of the system, as well as the efficacy of the active compensation of passive dynamics (ACPD).

### Vanderbilt Lower-Limb Exoskeleton

The Vanderbilt exoskeleton [1, 10] is shown in Fig. 3(a). The exoskeleton is a fully powered lower limb orthosis with right and left powered hip and knee joints. The exoskeleton has a mass of 12 kg (26.5 lb), incorporates brushless DC motors and backdrivable transmissions at each of the four joints, and is powered by a lithium polymer battery contained within the hip piece of the unit. The exoskeleton can be used with a standard ankle foot orthosis (AFO) if needed.

## Gait Phase Detection

In order for a system to cooperatively offer assistance to a user, it is necessary for the system to change its behavior at certain critical points in the gait cycle. These points include heel strike, toe off, and reversal of joint direction of motion. For this application, the authors have divided the gait cycle into 4 phases where the behavior of the device is expected to remain relatively consistent during each phase, and change at each phase transition. A state machine with switching conditions for the transitions is shown in Fig. 1.1. A discussion of the phases and transitions follows.

*Phase 0 (heel strike through mid-stance)* - Enters phase by exceeding a threshold in acceleration along the leg axis, as measured by an accelerometer on the exoskeleton. During this phase the knee remains essentially fully extended, and the hip transitions from flexion to extension. The phase ends in a mid-stance configuration, when the center of mass of the body is essentially over the stance leg.

*Phase 1 (mid-stance through toe-off)*- Enters phase based on prescribed hip angle, as measured by hip joint angle measurement on the exoskeleton. During Phase 1 the hip continues to extend and the knee begins to flex slightly. This brings the center of mass anterior to the stance leg during double support. Toe off typically occurs at the end of this phase.

*Phase 2 (early swing)* – Enters phase based on angular velocity of hip reversing direction. Phase 2 is considered the first part of swing phase. In this phase the hip and knee flex to bring the foot upward and forward and allow for toe clearance.

*Phase 3(late swing)* – Enters phase based on angular velocity of knee reversing direction. Phase 3 is the second part of swing phase and is characterized by rapid knee extension and maximum extension in the hip. The phase ends at heel strike.

To evaluate the accuracy and consistency of the phase tracking system, a healthy subject was asked to walk on a treadmill while wearing the exoskeleton. The subject was instructed to walk for 3 minutes at a velocity of 0.67 m/s (1.5 MPH), as measured by the treadmill. This speed was estimated to be a representative speed for the intended patient population. Joint angles and estimated phase of gait from the

exoskeleton were recorded. The exoskeleton was set in a passive mode so that there was no assistance of any kind. Data for ten consecutive strides were extracted and analyzed (Fig. 1.2). As indicated by the figure, the gait phase detection approach provides consistent identification of the significant phases of level walking.

### Active Compensation for Passive Dynamics

The exoskeleton prototype (Fig. 1.3) imposes undesirable passive dynamics on the user via three primary effects. First, the system has a mass of 12 kg, and therefore adds significant weight to the lower body of the user, potentially increasing the hip torque required to raise the knee by flexing the hip. Second, the links and motors add significant rotational inertia about the joints, primarily resulting from the motor rotor inertia as reflected to the joint through the backdrivable transmission. The reflected inertia is especially apparent at the knee, presumably due to the greater angular accelerations experienced by the knee relative to the hip joint [62]. Third, the system introduces friction at each joint, which again is most apparent at the knee joint, presumably due to the greater angular velocities at the knee joint (relative to the hip) [62]. While complete elimination of these passive dynamic contributions is unlikely, it is possible to reduce the effects of the passive dynamics so that the gait of a healthy subject approaches that of his or her gait without the exoskeleton. In the following two subsections, the results of two experiments demonstrate that the ACPD controller is effective in reducing the effect of the exoskeleton's passive dynamics on the user.

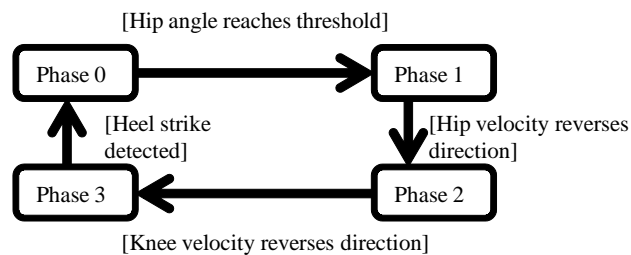

Figure 1.1. Simplified state machine model for phase recognition. Guard conditions are shown in brackets along each transition.

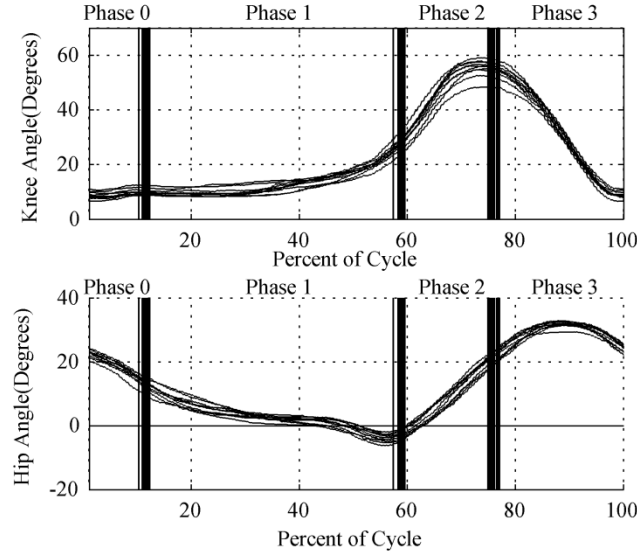

Figure 1.2. Knee and hip angles recorded for ten consecutive strides walking on a treadmill at 0.67 m/s. Vertical lines indicate transition points between labeled phases for all 10 strides. The Phase 3 to Phase 0 transition occurs at heel strike, and therefore at the 100% mark in all ten strides. Flexion is defined as positive.

### Gravity Compensation

Since the great majority of the exoskeleton mass is located in the respective thigh links (approximately 4.1 kg per thigh link), the primary intention of gravity compensation is to minimize hip joint effort required to flex the hip, and thus raise the thigh segment through the gravitational field. As such, the exoskeleton hip joint torque is supplemented with a compensatory torque,

$$\frac{1}{2} \times l \times m \times g \times \sin \alpha \tau_g = \frac{lmg \sin \alpha}{2} \quad (1)$$

where  $m$  is the mass of the thigh link,  $l$  is the length of the thigh segment,  $m$  is assumed to be distributed uniformly along  $l$ ,  $g$  is acceleration due to gravity, and  $\alpha$  is the angle of the thigh link relative to the vertical. Note that the latter is measured via an accelerometer on the exoskeleton, as described in [8].

To evaluate the efficacy of the gravity compensation algorithms, electromyogram (EMG) data from three healthy subjects were collected and analyzed for three conditions corresponding to no exoskeleton,



exoskeleton without gravity compensation, and exoskeleton with gravity compensation. Subject ages ranged from 24 to 26 years, and subjects 1, 2, and 3 had masses of 64 kg, 77 kg, and 100 kg respectively. For the experiment each subject was asked to stand upright and elevate their dominant side leg to approximately 75 degrees from the vertical while EMG data were recorded from the rectus femoris muscle in the thigh.

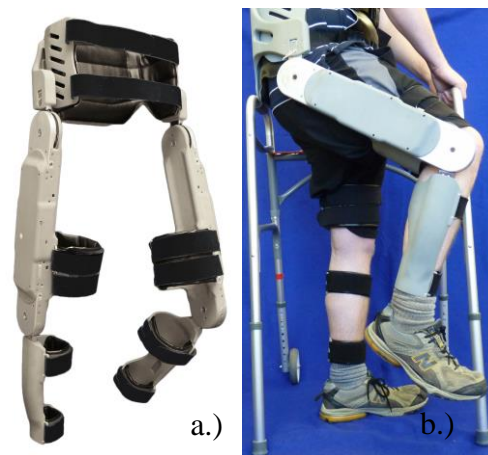

Figure 1.3. a.) Exoskeleton prototype. b.) Experimental setup for EMG recordings. Subjects were asked to raise their dominant leg to an angle of approximately 75 degrees from the vertical position. Real-time readouts of absolute thigh orientation provided subjects with feedback to ensure an appropriate angle was maintained. Subjects grasped a walker to ensure they could easily maintain balance. EMG signal wires and exoskeleton data-tether not pictured.

Subjects were instructed to allow their lower leg to remain passive. A real-time estimate of the thigh angle relative to gravity was produced on a monitor so that the subjects could easily adjust to maintain the appropriate angle. Fig. 1.3 shows the exoskeleton and experimental setup. Subjects were asked to keep their limb elevated for ten seconds before being instructed to relax. In between trials subjects were allowed to rest, and were instructed to alert the experimenter immediately if they felt they were beginning to fatigue. This procedure was carried out 12 times for each of 3 conditions: no exoskeleton, and the exoskeleton with

and without compensation for gravity. “No Compensation” refers to a non-assistive setting in which the exoskeleton remains passive. In the “With Compensation” setting, the exoskeleton provides torque equivalent to 100% of its estimated mass. Trials were performed in a semi-randomized order to ensure results were unaffected by trial order.

EMG signals were low-pass filtered at 500Hz, high-pass filtered at 10Hz, and sampled at 1000Hz. These data were rectified and low-pass filtered at 3Hz to produce an envelope. For each trial a four second window was selected from the middle of the trial, and the EMG signal was averaged over that window. The mean of the four second windows was averaged for ten trials to produce an average EMG magnitude for each of the 3 settings. Fig. 1.4 shows the difference between the average EMG magnitude for each exoskeleton assistance setting, relative to the case without the exoskeleton. Thus, the values indicate the respective increase in EMG amplitude relative to the normal condition. These results are reiterated quantitatively in Table 1. As evident by the results, the presence of gravity compensation substantially reduces the effective weight of the exoskeleton (although it does not return it to the EMG level measured in the absence of the exoskeleton). Note that, in the absence of a subject within the exoskeleton, the gravity compensation fully compensates for the gravitational effects at the hip joint (i.e., the exoskeleton hip joint will remain in a given configuration in the presence of gravity). As such, it is hypothesized that a portion of the elevated EMG seen in the gravity compensation experiment was due to the (sagittal plane) constraints on motion imposed by the exoskeleton. Specifically, slight changes in the plane of movement may increase the level of muscular co-contraction required to flex the hip joint, and therefore the presence of the exoskeleton may slightly increase quadriceps EMG during hip flexion due to secondary factors. Although the exoskeleton is easily capable of providing additional gravity compensation (which can offset the increase in EMG), the authors chose instead to maintain the level of gravity compensation that is appropriate in the absence of a subject, and thus used the settings indicated in Fig. 1.4 (and Table 1) in the level walking experiments described subsequently.

## Inertia and Friction Compensation

In order to reduce the effects of added inertia, hip and knee joint torques are supplemented in proportion to the respective angular acceleration of the joint,

$$\tau_i \propto \frac{d^2}{dt^2}(\theta) \quad (2)$$

where  $\theta$  is the angular position of that joint, and where the constant of proportionality (i.e., the effective rotational inertia) was determined experimentally. In order to reduce the effects of added friction, hip and knee joint torques are supplemented in proportion to the respective angular velocity of the joint,

$$\tau_f \propto \frac{d}{dt}(\theta) \quad (3)$$

where the constant of proportionality (i.e., the damping coefficient) was determined experimentally. The total passive dynamics compensation therefore consists of the application of equation 1 at the hip joints, and the sum of equations 2 and 3 at the knee joint.

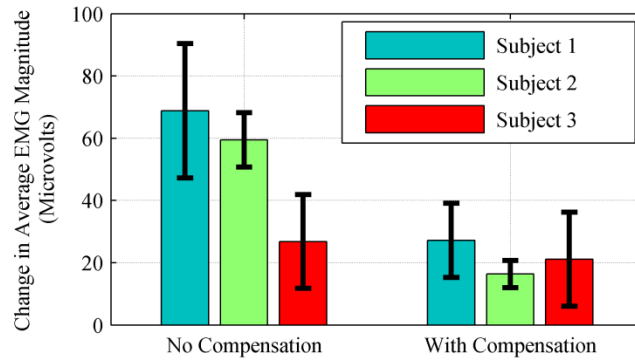

Figure 1.4. Change in average EMG from no-exoskeleton condition. EMG signals were recorded from the rectus femoris while the subjects' legs were raised to 75 degrees from the vertical. Values indicate an increase in EMG from the no-exoskeleton condition. Each bar indicates an average over ten trials.

TABLE 1  
Percent Change in EMG Magnitude for each Assistance  
Condition

Subject	Average EMG magnitude for “No Exoskeleton”	No gravity compensation	With gravity compensation
1	34 $\mu$ V	204%	81%
2	32 $\mu$ V	184%	51%
3	66 $\mu$ V	40 %	32%

### Methods and Results

To test the efficacy of the ACPD controller, kinematic data from the hip and knee joints during gait were recorded for a single healthy subject, walking under three conditions: no exoskeleton (unaffected walking), passive exoskeleton, and exoskeleton with ACPD. In the passive-exoskeleton condition the subject wore the exoskeleton, but gravity, inertia, and friction compensation were disabled. In these experiments, the subject walked on a treadmill at 0.67 m/s for 3 minutes for each condition. The subject was a 24 year old male with body weight of 100 kg and height of 1.85m. In these experiments, the subject was instructed to walk naturally in all cases. For the no-exoskeleton condition, hip and knee angle data were collected using a motion capture system (OptiTrack 12-camera motion capture with ARENA software). For the passive-exoskeleton and exoskeleton-with-ACPD conditions, hip and knee joint angle data were recorded from the exoskeleton. Fig. 1.5 shows averaged knee and hip angle for ten consecutive strides in each condition. It is clear from the data that the joint trajectories with ACPD are much closer to the unaffected walking than those of the exoskeleton without compensation (i.e., the passive exoskeleton). This trend is especially clear in the knee joint, where the average peak in the knee angle is severely reduced for the passive-exoskeleton trajectories compared to the other two sets. Table 2 summarizes the respective ranges of motion of the knee and hip joint during walking at this speed for the two cases of wearing the exoskeleton, relative to case of unaffected walking. As indicated in the table, when wearing the exoskeleton without passive dynamics compensation, the knee joint achieved 73% of its normal range of motion, while the hip joint achieved 111%, indicating the passive dynamics had a significantly effect on knee joint motion, and relatively little

impact on hip joint motion. With the addition of the ACPD controller, the knee joint achieved 96% of its normal range of motion, while the hip joint achieved 108%. As such, the joint range of motion with ACPD is nearly unaffected when walking with the exoskeleton. These results suggest the efficacy of the ACPD, and further suggest that with such compensation, a user is able to perform level walking in the exoskeleton without substantially affecting the user’s natural gait dynamics.

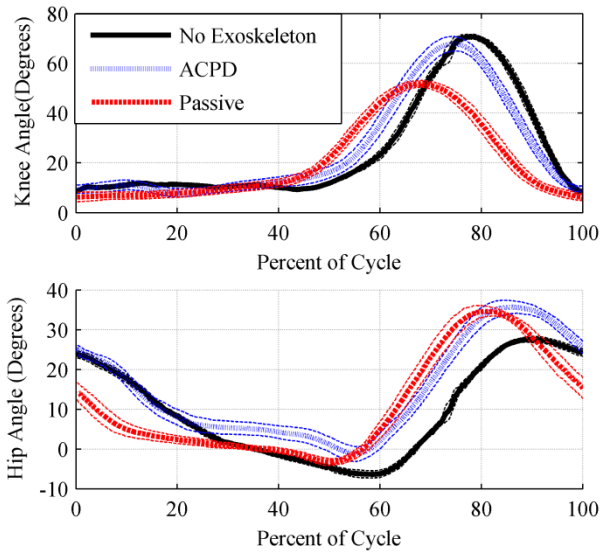

Figure 1.5. Averaged knee and hip angles for ten consecutive cycles with standard deviation shown. Shown are no-exoskeleton, exoskeleton-with-ACPD, and passive-exoskeleton conditions. The maximum knee flexion for the passive-exoskeleton condition is significantly reduced in comparison to the other two conditions, and hip kinematics suggest that the ACPD condition matches the no-exoskeleton condition more closely as well.

TABLE 2  
Range of Motion Analysis for Exoskeleton

Condition	Percent Range of Motion	
	Knee	Hip
Passive	73%	111%
ACPD	96%	108%

## Conclusion

The authors present the implementation of two important components of a lower limb exoskeleton for gait assistance in persons with locomotor deficits. The first is gait phase detection, and the second is active compensation for passive dynamics. In this paper, the authors describe an implementation of each, and provide experimental results indicating the respective efficacy of each component. Future work includes adding a gait assistance component to the exoskeleton, and assessing the ability of the exoskeleton to provide appropriate gait assistance to persons with locomotor deficit.

## ADDENDUM

Ultimately, gravity compensation proved to be quite important and was implemented in the NTB controller for gait therapy. Compensation of damping and inertia proved unnecessary when walking at the slow gait speeds (0.1m/s to 0.4m/s) seen in the target population. As such, these components were not implemented in the NTB controller. This study also demonstrated that reliable gait-cycle phase division was possible with the existing exoskeleton sensors. Design and implementation of the NTB controller's assistive components followed. These components are detailed in Chapter IV.

## CHAPTER III

### PHYSIOLOGICAL SIGNAL RESPONSE TO TASK ENGAGEMENT

Manuscript II is presented in this chapter of the dissertation and is not part of the development of the NTB controller. Rather, this work was performed in order to explore a novel method of controller evaluation. Specifically, the authors were exploring the development of an objective means of quantifying task engagement in a subject participating in a multi-limb-coordinated motor-learning task. One advantage that the NTB controller may offer is increased patient engagement. Relative to trajectory-based systems which may drive patients through the same cycles regardless of participation, the overground exoskeleton controller (described in full detail in the next chapter) will not provide assistance unless the patient is actively attempting to walk. In a broader sense, engagement in therapy is recognized as an important factor in the rehabilitation process, so a method for the objective evaluation of patient involvement would be valuable in determining which interventions elicited that engagement. The experiment presented in the manuscript in this chapter established that in a multi-limb-coordinated motor-learning task, certain physiological signals correlate with task engagement. A version of this manuscript which lacked an analysis of control data was presented at the *2015 Annual International Conference of the IEEE Engineering in Medicine and Biology Society* (EMBC 2015). The complete manuscript with an analysis of the control data is presented below. This manuscript is currently in preparation for publication as a journal article.

#### MANUSCRIPT II: PHYSIOLOGICAL SIGNAL RESPONSE TO VARYING TASK ENGAGEMENT IN A MULTI-LIMB COORDINATED MOTOR-LEARNING TASK

##### Abstract

Task engagement is widely recognized in the physical rehabilitation community as essential to neuromuscular recovery. However, numerous obstacles make objective analysis of task engagement difficult. Previous studies have reported correlation between certain physiological signals - namely heart

rate (HR), skin conductance level (SCL), and facial electromyogram (EMG) – and mental effort. In this paper the authors analyze the extent to which these physiological measurements could be used as an indicator of task engagement in a multi-limb-coordination motor-learning task. Nine subjects were asked to play a video game which required them to use both arms and one leg to activate an electronic drum kit at varying levels of difficulty. Physiological signals were recorded as the subject played. Statistically significant correlations relating HR, SCL, and EMG in corrugator supercilii to task difficulty were observed. Subjects were asked to return for a control experiment in which they played a simplified rhythm at various rates to analyze whether the correlations observed in the experimental condition were due to physical exertion. Analysis did not find statistically significant correlation between the task load of the simplified task and any of the measured signals.

### Introduction

Stroke affects over 800,000 people in the United States each year, resulting in over 400,000 patients requiring upper and/or lower limb rehabilitation [11]. In recent years, numerous new technologies have emerged to offer robotic assistance to patients undergoing rehabilitation [38-41, 63-65]. Although several reviews suggest that electromechanical devices, as a group, offer some benefit to patients recovering from stroke [52, 66], there is no general consensus on which of these new technologies offers the greatest rate of improved functional outcomes for patients.

Patient effort during physical therapy is believed to be an important factor in the rehabilitation process. As such, several tools have been developed to quantify patient engagement based on patient questionnaires or physical therapist (PT) evaluation [67-69]. Patient effort during physical therapy has also been shown to correlate with improved functional outcomes in patients undergoing rehabilitation [68, 70]. Therefore, a method to analyze the level of patient effort during physical therapy could potentially be used to predict which therapies would be most beneficial to a patient population. Unfortunately, newly-developed, robotically-assisted therapies may obscure the patient's level of engagement from the PT; e.g.



an exoskeleton may make it difficult to differentiate between patient effort and exoskeleton assistance. Further, patients recovering from stroke frequently suffer from cognitive impairment (46% of patients) and/or aphasia (19% of patients) [11], potentially limiting the efficacy of patient questionnaires.

Several physiological signals have been shown to correlate with mental effort when recorded from subjects performing various tasks. EMG amplitude in the facial muscles frontalis and corrugator supercilii has been shown to increase with task load during a two-choice serial reaction task [71]. Skin conductance has been shown to increase when the subject experiences mental stress [72]. Heart rate (HR) has been shown to increase with stress but decrease with visual attention [73], and heart rate variance (HRV) has been shown to decrease with cognitive load, although HRV is known to be altered in patients with stroke and was therefore not selected for analysis in this study [74, 75]. Some work has been performed which suggests that physiological signals can be used to estimate psychological state while using a rehabilitation robot [76].

This paper describes an experiment designed to determine whether these same physiological signals could be used to evaluate a subject's level of mental engagement in a multi-limb-coordination motor-learning task. In the experimental condition nine healthy subjects performed a motor-learning task with varying degrees of difficulty while physiological signals were recorded. In a control experiment, subjects returned for a second session in which they played a simplified rhythm with no variation at the minimum, maximum, and median rates they had played in the previous session. This was done in order to analyze what impact physical exertion had on the signals.

### Methods

Subjects completed a multi-limb motor-learning task in which they were asked to play the Rock Band™ video game. Subjects were asked to strike the pads of a simplified, electronic drum set with drum sticks, while also activating a drum pedal with their foot (i.e. the Rock Band™ drum controller), in time with onscreen instructions. Objects of four colors appeared in four onscreen locations to indicate when the four

corresponding drum pads should be activated. A fifth object, a gold bar, indicated when the foot pedal should be activated. Visual and auditory feedback from the Rock Band™ software indicated when subjects hit or missed each commanded strike or pedal activation (Figs. 2.1 and 2.2). Vanderbilt's Institutional Review Board approved all experimental procedures involving human subjects described in this paper.

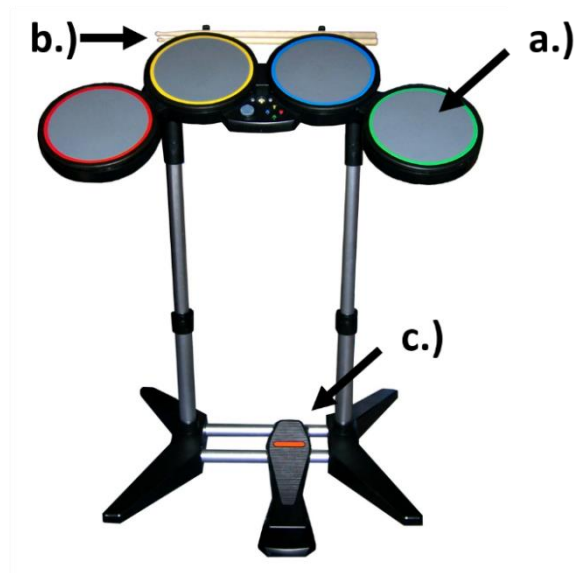

Figure 2.1. The Rock Band™ drum controller. a) Pads are struck with b.) wooden drum sticks. c) Foot pedal is activated with the dominant foot.

### Equipment

EMG signals were recorded from the muscles frontalis and corrugator supercilii, both facial muscles in the forehead, using BIOPAC Systems EL504 Ag/AgCl electrodes and a Texas Instruments ADS1298 analog-to-digital converter. EMG signals were amplified, high-pass filtered at a cut-off frequency of 20 Hz, and low-pass filtered with a cut-off frequency of 500 Hz. The signals were then rectified and low-pass filtered at a cut-off frequency of 5 Hz to produce an envelope of the electrical activity. Electrodes were placed to record from frontalis and corrugator supercilii as described by Van Boxtel and Jessurun [71]. SCL was recorded using a NeuLog™ Galvanic Skin Response Sensor with the electrodes attached to the

instep of the non-dominant foot as described by van Dooren et al [77]. This placement permitted the subject to use both drumsticks and activate the foot pedal without interference from the sensors. HR was recorded using a Garmin™ HRM1G Heart Rate Monitor.

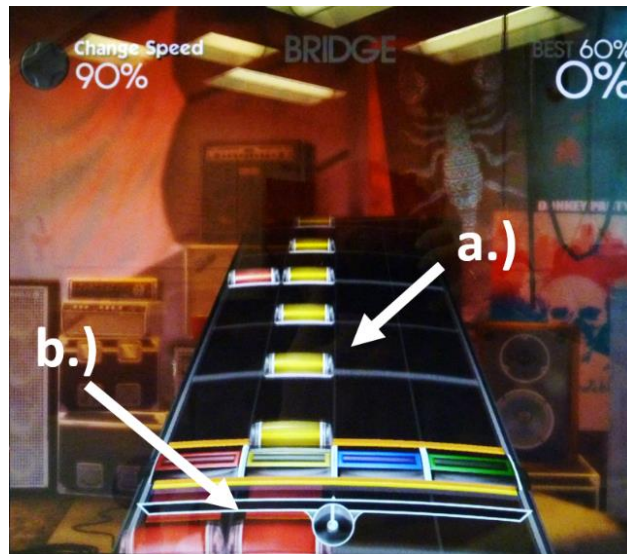

Figure 2.2. Display from the Rock Band™ video game. a) Drum pad objects indicate which controller pad should be struck. b) Missed notes change color, fade, and are accompanied by auditory feedback to indicate the error.

### Experimental Procedure

Before beginning the measurement phase, each subject was allowed to play for five to ten minutes in order to ensure they understood the game's onscreen commands. During this warm-up, subject performance (percentage of correct strikes) was recorded, and game speed was adjusted to suit the subject's ability. Subjects were then outfitted with recording devices for EMG, GSR, and HR recordings. Baseline recordings of all signals were taken with the subject resting. The subjects were then asked to complete a series of tasks which varied in difficulty and appeared in a randomized order. Each task consisted of playing a single level of the video game. The experimenter would begin the recordings and verbally signal the subject to begin

playing. Each task lasted three minutes, and subjects were verbally signaled to stop by the experimenter. Subjects were then allowed to rest until their HR returned to resting levels and their SCL level stabilized before beginning the next task. This was repeated until the subject had completed all nine tasks.

#### Control Procedure

Subjects were asked to return for a second session. During this second session, subjects were instructed to perform a simplified rhythm in which they alternated between striking the red and green pads simultaneously and activating the blue pad, yellow pad, and foot pedal simultaneously. Once subjects had mastered the rhythm they were outfitted with all recording devices and baseline recordings of all signals were taken with the subject resting. Subjects were then instructed to play the pattern in time with a metronome which was set to a frequency which reproduced the minimum SPM, maximum SPM, or median SPM rate at which the subject had played in the previous session. The experimenter would begin the recordings and verbally signal the subject to begin playing. The subjects were asked to keep time with the metronome for three minutes, at which time the experimenter verbally signaled for them to stop. Subjects then rested until HR returned to resting levels and SCL stabilized before continuing. This was repeated until subjects had performed all three tasks. The order in which the minimum, maximum, and median rates were presented was randomized for each subject to reduce any ordering effects in the data. Although data were recorded and plotted (Fig. 2.4) with SPM representing task load, the sequence of strikes was so simplified that task difficulty should be considered to be minimal, and constant across all rates.

#### Statistical Analysis

The EMG amplitudes measured from the frontalis and corrugator supercilii muscles were averaged over the last two minutes of each task and normalized to the maximum EMG recording to reduce inter-subject range differences for comparison (note that this procedure creates a data point with a normalized EMG amplitude of exactly 1 for each subject). Skin conductance level was averaged over the last two minutes of

each task and normalized as a percentage of the SCL value recorded just before beginning the task. HR was averaged over the last two minutes of each recording and normalized to the baseline rate for each subject. Data from each session were tested independently for correlation between task difficulty - measured in strikes per minute (SPM) - and EMG, HR, and SCL. Correlation was calculated using Spearman's  $\rho$ . The significance level (p-value) was set at .05 for all tests. In order to minimize the familywise error rate with multiple (four) comparisons, the Bonferroni correction method [78] was employed, which sets the significance level at  $.05/4 = .0125$ . Correlation coefficients are summarized in Table I. Scatter plots of the associated data points used to perform the analyses for the experimental data are presented in Fig. 2.3. Scatter plots for the data points used in the analysis of the control data are presented in Fig. 2.4.

### Results

During the experiments, EMG amplitude in the corrugator supercilii was found to correlate negatively with increasing task load ( $\rho = -.39, p < .001$ ). However, no statistically significant correlation was observed in the EMG of frontalis. HR demonstrated a positive correlation with increasing task load ( $\rho = 0.32, p < .01$ ), as did SCL ( $\rho = 0.29, p < .01$ ).

TABLE 3  
Results of Statistical Analysis

Spearman's $\rho$ Correlation of Physiological Signals with Task Load in Experimental Condition		
Physiological Signal	$\rho$	p-value
EMG Amplitude Corrugator Supercilii ( $\mu V$ )	-0.39	<.001
EMG Amplitude Frontalis ( $\mu V$ )	-0.01	.95
Heart Rate (BPM)	0.32	<.01
Skin Conductance Level ( $\mu S$ )	0.29	<.01
Spearman's $\rho$ Correlation of Physiological Signals with Task Load in Control Condition		
Physiological Signal	$\rho$	p-value
EMG Amplitude Corrugator Supercilii ( $\mu V$ )	-0.09	.65
EMG Amplitude Frontalis ( $\mu V$ )	0.10	.61
Heart Rate (BPM)	0.25	.21
Skin Conductance Level ( $\mu S$ )	0.08	.67

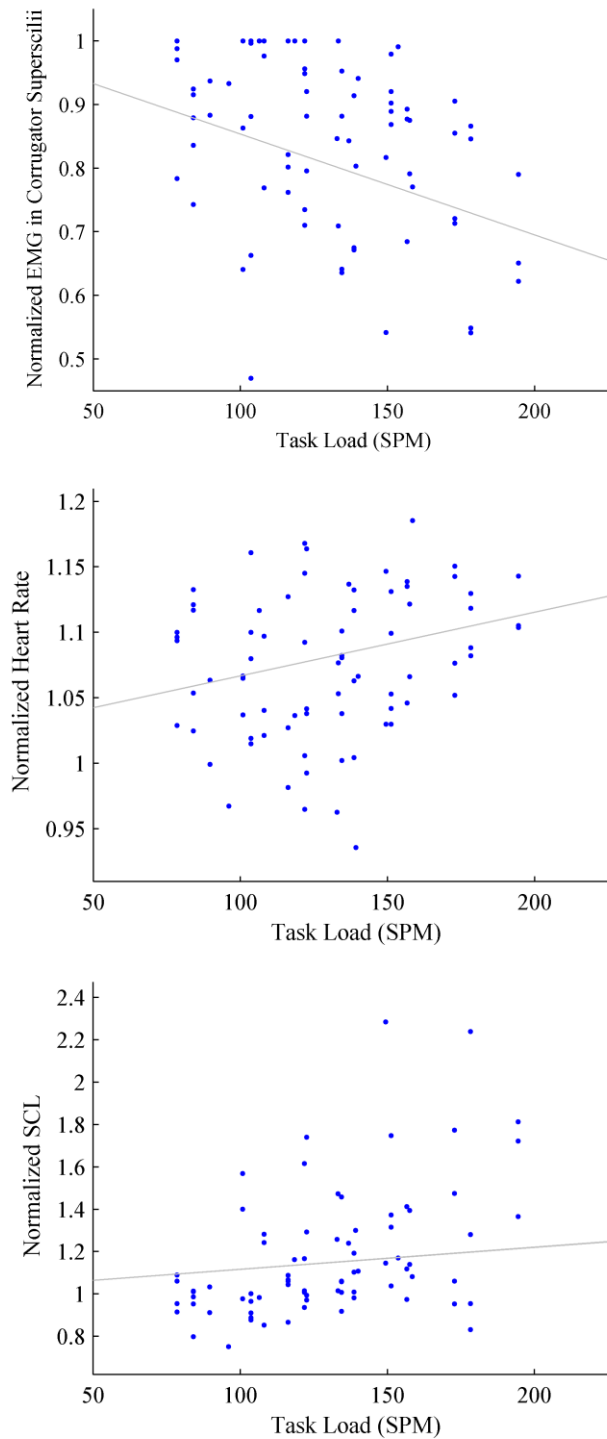

Figure 2.3. Plot of experimental condition task load vs normalized EMG amplitude in corrugator superscillii (top), normalized HR (middle), and normalized SCL (bottom), each with a least-squares-fit line. Each point represents the average value from two minutes of a single recording. Some outliers not pictured.

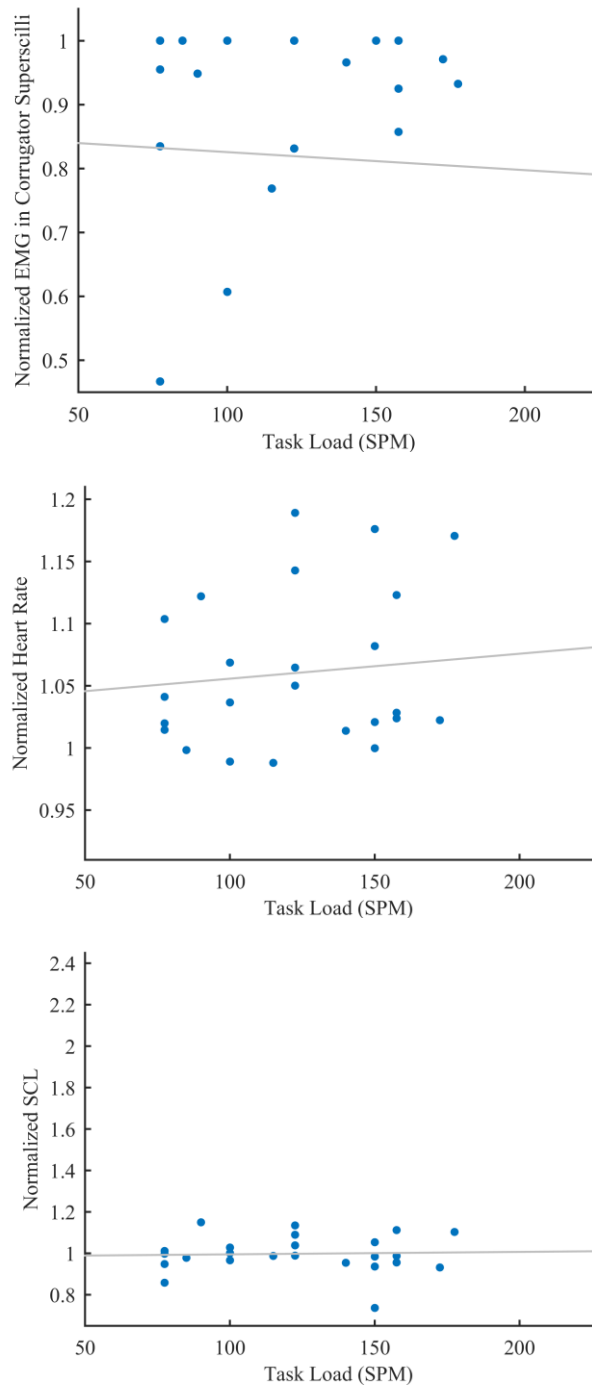

Figure 2.4. Plot of control condition task load vs normalized EMG amplitude in corrugator superscilli (top), normalized HR (middle), and normalized SCL (bottom), each with a least-squares-fit line. Each point represents the average value from two minutes of a single recording. Some outliers not pictured.

In the control condition, no statistically significant correlation was observed between the task rate (SPM) and any physiological signal. Further, the observed correlation coefficients ( $\rho$ ) were considerably smaller in the control condition than in the experimental condition (with the exception of HR, which was only slightly smaller than in the experimental condition). Values of  $p$  and  $\rho$  are summarized in table I.

### Discussion

Analysis demonstrated that a statistically significant correlation exists between task load and certain physiological signals; namely EMG amplitude in corrugator supercilii, SCL, and HR. Although all three of these signals correlated with task load, EMG in the corrugator supercilii demonstrated the strongest correlation, suggesting that it may be the signal best suited to task-engagement analysis. It is worth noting that the negative correlation between corrugator supercilii and task load agrees with findings reported in [71], where EMG amplitude appears to decrease as the task load exceeds the maximum rate that the subject can comfortably perform. In the control condition, subjects reproduced the level of physical exertion achieved in the experimental condition, but no statistically significant correlation between the task rate and any physiological signal was observed. This suggests that the response seen in the experimental condition was due to increasing mental engagement and not simply due to increased physical exertion.

While the results presented herein are promising, future work should be performed in which task load is more rigorously defined. The Rock Band™ system was selected for its convenience because it provided onscreen instructions with visual and auditory feedback. However, while the authors used strikes per minute to quantify task load, the SPM metric is not a perfect measure of difficulty. As demonstrated by the results of the control experiment, a simple rhythm played at higher speeds may be easier for a subject than a syncopated rhythm played at slower speeds. The subjective nature of the difficulty levels in Rock Band™ may have weakened the correlation between task load and the observed physiological signals. By more clearly defining task difficulty, it may be possible to further improve the correlation between physiological



signals and task engagement, making analyses like these a potential tool in evaluating subject engagement in a motor-learning task.

### Conclusion

EMG measurement of the corrugator supercilii muscle, HR, and SCL were shown to correlate with task load in a multi-limb-coordination motor-learning task, while EMG measurement in the frontalis muscle was not. Future work with a rigorously defined task load should be performed in order to further inform the extent to which these measurements might be an effective assessment of patient engagement in a rehabilitation task.

### ADDENDUM

The findings reported in Manuscript II suggest that there is a statistically significant correlation between task engagement and EMG amplitude in corrugator supercilii, heart rate, and skin conductance level. The lack of statistically significant correlation in the control data further suggested that there was little to no reason to believe this correlation was due to physical exertion. Unfortunately, the Spearman's  $\rho$  coefficients were lower than anticipated. This could be due to the measure of task-load used in the experiment, indicating that further experiments should be performed. Alternatively, the low correlation value could be due to increasingly erratic behavior in the signals at higher task-loads. This latter possibility is supported by van Boxtel and Jessurun's work which shows large spikes present in the EMG recordings from corrugator supercilii when the task load exceeds the point at which the subject can perform the task with 100% accuracy [71]. Whatever the cause, the low correlation values indicate that this line of investigation will need to be pursued further before physiological signals can be used to draw conclusions about task engagement for an individual subject.

## CHAPTER IV

### NON-TRAJECTORY BASED CONTROLLER DEVELOPMENT AND PRELIMINARY STUDY

With active cancellation of passive dynamics in place and tested, development of the assistive components of the NTB controller began. The NTB controller was designed with the philosophy that it should offer two types of assistance; the ability to encourage joint excursion during the swing phase of the gait cycle, and the ability to reinforce joint-stability (i.e. prevent buckling) in the stance limb during the single-support phase. Also, to permit the controller to accommodate a range of patients it is necessary that the controller offer a significant amount of adjustability as the impairments resulting from CVA are deeply heterogeneous. By using the gait-cycle division methods developed in Manuscript I, the NTB controller is able to provide assistance to targeted portions of the step cycle, resulting in highly specific assistance. The partial limb-weight compensation, joint stability reinforcement during stance, and feedforward torque pulse components that comprise the NTB controller are detailed fully in Manuscript III. The manuscript also presents the results of a small pilot study in which the NTB controller was implemented on the Vanderbilt Exoskeleton and tested with three subjects with gait impairment as the result of CVA. The study showed that subjects with hemiparesis were able to practice gait in the controller, and that gait training in the exoskeleton produced significant changes in the gait patterns of the users following a one-hour training session. This manuscript was published in the 3rd issue of the 24th volume of *IEEE Transactions on Neural Systems and Rehabilitation Engineering*.

# MANUSCRIPT III: DEVELOPMENT AND PRELIMINARY ASSESSMENT OF A NON-TRAJECTORY BASED CONTROLLER FOR A POWERED LOWER-LIMB EXOSKELETON

## Abstract

This paper presents a control approach for a lower-limb exoskeleton intended to facilitate recovery of walking in individuals with lower-extremity hemiparesis after stroke. The authors hypothesize that such recovery is facilitated by allowing the patient rather than the exoskeleton to provide movement coordination. As such, an assistive controller that provides walking assistance without dictating the spatiotemporal nature of joint movement is described here. Following a description of the control laws and finite state structure of the controller, the authors present the results of an experimental implementation and preliminary validation of the control approach, in which the control architecture was implemented on a lower limb exoskeleton, and the exoskeleton implemented in an experimental protocol on three subjects with hemiparesis following stroke. In a series of sessions in which each patient used the exoskeleton, all patients showed substantial single-session improvements in all measured gait outcomes, presumably as a result of using the assistive controller and exoskeleton.

## Introduction

Each year approximately 800,000 people in the US suffer a stroke or cerebrovascular accident (CVA), of which approximately 660,000 survive [59]. Of these, approximately 200,000 annually are affected by lower-extremity hemiparesis to an extent that prevents walking without assistance six months after (i.e. by the time they enter the chronic stages of stroke) [79-81]. The inability to walk unassisted has an obvious impact on an individual's independence and community dwelling capability, and thus quality of life and continued health. Similarly, impaired balance and compromised walking ability increase the incidence of falls and resulting fractures [82-88].

Typical gait deficits in lower-limb-affected post-stroke individuals involve a combination of impaired muscle strength, coordination and proprioception, and often excessive muscle tone in the paretic limb. The two most immediate biomechanical effects of these impairments are instability of the paretic leg during the stance phase of gait (i.e., the potential of knee instability in flexion or hyperextension), and insufficient foot clearance on the paretic side during the swing phase of gait. In order to mitigate these deficits, post-stroke individuals typically employ compensatory actions. These include asymmetric spatial and temporal step lengths as well as a substantial frontal plane lean toward the non-paretic leg, both of which bias the individual away from loading the paretic leg in stance. Additionally, hip circumduction of the paretic leg during swing phase and ankle plantarflexion of the non-paretic ankle during stance (i.e., vaulting on the non-paretic leg), both facilitate foot clearance of the paretic leg during swing.

Given these biomechanical deficits exhibited by hemiparetic individuals, the biomechanical movement objectives of post-stroke gait training primarily entail improving load acceptance on the paretic leg during stance, which results in improved spatial and temporal step symmetry and generally greater stride length, and improving foot clearance of the paretic leg via increased hip and knee flexion of the paretic leg during swing. These therapeutic objectives have traditionally been pursued by a combination of physiotherapy (e.g., mat exercises, weight training, use of fitness equipment) and assisted overground gait training, which may be supplemented by assisted treadmill training. Two methods of assisted treadmill training are manually and robotically assisted body-weight-supported treadmill training (BWSTT). In the manual version of this therapy, a portion of a patient's body weight is suspended above a treadmill through an overhead suspension point, while one or more therapists manipulate a patient's pelvis and limbs as needed to facilitate treadmill walking. Robotic versions of this therapy incorporate robotic manipulation of the legs in place of manual manipulation. Such systems may provide more consistent interaction with a patient, and in most cases decrease the number of therapists required to provide BWSTT. As described in a recent review article [89], various methods have been proposed to control the patient-robot interaction in robotically-assisted BWSTT systems. Some representative methods include force-field-based control methods which guide the user along desired trajectories using simulated walls around a pre-selected

footpath [40, 41]; record-and-replay impedance based methods to create subject specific trajectories [37]; and model-based methods which selectively target specific sections of the gait cycle [38, 39].

Recently, lower limb exoskeletons have begun to emerge. Unlike robotically assisted treadmill systems, lower limb exoskeletons are wearable robots, and as such enable overground rather than treadmill-based locomotion. Overground walking, particularly for severely hemiparetic individuals, can be characterized by a highly irregular gait speed, with considerable pauses between movements, as dictated by the movement volition, and balance and weight shifting needs of the individual. Treadmill-based systems can be adapted to provide adaptive speed capability (see, for example, [90], in addition to a large body of patent literature on the topic). Such systems, however, distort the dynamics of overground locomotion during periods of belt acceleration and deceleration when the belt speed changes. As such, for highly irregular gait, such as that which might be observed in a severely hemiparetic individual, a treadmill-based system is unable to accurately represent the dynamics of overground walking. In addition to resulting in unnatural perturbations in movement, the distortion in dynamics associated with an irregular belt speed also presents a distortion in vestibular information presented to the individual. The distortion in vestibular information, together with the associated lack of visual flow, further impairs the ability of a treadmill system to emulate overground walking with irregular gait speed.

In addition to limitations associated with reproducing the dynamics of highly-irregular gait, treadmill-based systems are typically limited with respect to their ability to provide assistive forces that are fully consistent with the biomechanics of locomotion and balance. Specifically, in order to provide assistance that is fully consistent with the biomechanics of locomotion and balance, the assistive forces between the environment and the individual can only occur between the individual's feet and the ground. Since a wearable exoskeleton (as defined here) has no attachment points to the inertial reference frame, it must react assistive components that it provides exclusively between the individual's feet and the ground (which is fully consistent with the biomechanics of locomotion and balance). Treadmill-based systems, conversely, typically entail at least one point of constraint between the individual and treadmill (i.e., inertial reference) frame beyond the foot/floor contact points. The constraint between the treadmill frame and the

robot will introduce a constraint force that is not consistent with the biomechanics of overground locomotion and balance, and therefore can presumably interfere with the relearning of or recovery of balance. In the case of a manually-assisted treadmill system, this constraint is typically an overhead suspension point, which imposes body-weight support from the overhead point down, and as such introduces an artificially stabilizing effect. In the case of a robotically-assisted treadmill, the nature of this constraint depends upon the extent to which the robotic portion is constrained relative to the treadmill (and inertial reference) frame. If the robotic portion of the treadmill is fully unconstrained relative to the treadmill frame (i.e., the robotic portion is essentially an exoskeleton mechanically decoupled from the treadmill frame), then no artificial constraint forces will be present, and as such no artificial force components will interfere with balance dynamics (i.e., the body-weight support will be provided in a manner fully consistent with balance dynamics, less the irregular belt speed issue previously discussed). If however, the robotic portion is coupled to the treadmill frame by at least one kinematic constraint, the system will introduce at least one artificial component of force that is not representative of the balance dynamics entailed in overground standing and walking. Depending on the rehabilitation objectives, such constraints could be an asset. If relearning balance for purposes of overground standing and walking is the primary objective, however, these artificial constraints constitute a distortion of overground balance dynamics, which presumably can interfere with the relearning of such balance.

Despite the efficacy of the aforementioned control methods [12-17] in governing interaction between the patient and robot in robotically-assisted BWSTT systems, such methods are less well-suited to walking overground in an exoskeleton. Specifically, these control methods either dictate or substantially influence the spatiotemporal nature of leg movement or foot path (i.e., they have a substantive influence on either step length or step time). In the case of treadmill walking, desired step length and/or time is consistent and generally known. Further, the presence of overhead body-weight support mitigates the need to maintain balance. In the case of overground locomotion, however, enforcing or encouraging a given leg movement or footpath will generally present a balance perturbation, which may interfere with a patient's ability to select step length and/or time, and thus interfere with the ability of the user to maintain balance when

walking. As such, a control methodology for gait assistance for an exoskeleton should ideally assist movement, without governing the spatiotemporal nature of the footpath, such that the patient is able to provide the movement coordination required to maintain balance (i.e., the patient must select a step length and time that maintains his or her zero-moment-point within his or her support polygon). In this manner, the system facilitates balance recovery, and avoids substantial balance perturbations. This paper describes a control approach that provides this objective. Specifically, the approach provides floor-referenced walking assistance without substantially affecting a user's ability to select a desired step length or time. Following a description of the control structure, the authors describe the implementation of the controller in a lower limb exoskeleton, and additionally describe some preliminary results of implementing the exoskeleton and controller on three post-stroke subjects.

#### Controller to Facilitate Recovery following Stroke

The general intent of the exoskeleton is to help a patient to recover the neural coordination associated with walking. The authors hypothesize that such recovery is facilitated by allowing the patient rather than the exoskeleton to provide movement coordination. Specifically, coordination is considered a mapping between sensory input and motor output in the sense of a neural network, wherein weights in the neural network are incrementally adjusted based on iterative error correction. Consistent with a Hebbian model of learning (i.e., "neurons that fire together wire together"), adjustment of synaptic weights requires associating an afferent pattern of neural *information* with an efferent response. Thus, it is conjectured that having the patient provide movement coordination, and allowing the patient to incur and correct for errors in that coordination, will facilitate neural recovery (i.e., will facilitate the formation of appropriately weighted coordination maps). As such, the objective of the control approach presented here is to provide to the patient movement assistance (to compensate for muscle weakness and to enhance stability), without providing a desired movement path or trajectory.

The resulting controller, described subsequently, consists of the combination of three types of behaviors: gravity compensation, feedforward movement assistance during swing, and knee joint stability reinforcement during stance. The gravity compensation component consists of two sub-components: full gravity compensation for the mass of the exoskeleton, and partial gravity compensation for the patient's leg mass during the swing phase of gait. The feedforward movement assistance consists of torque pulses that assist weak muscle groups when initiating or reversing joint movement at the beginning or middle of swing phase, as needed by the individual. The knee joint stability reinforcement takes the form of emulated spring-damper elements (similar to those used to simulate surfaces in haptic interfaces), which mitigates knee instability in flexion or hyperextension during the stance phase of gait. With regard to the previously stated control objectives (i.e., providing movement assistance without providing coordination or trajectory control), the gravitational components involve no prescribed trajectories. The torque pulse components during swing provide non-trajectory-based movement assistance, and specifically supplement movement already initiated by the user and vanish well in advance of the end of the respective movements. Finally, the knee joint stability reinforcement is a passive component that prevents knee joint buckling during stance, but otherwise involves no prescribed time-basis or trajectories. Thus, the combination of these control components provides the user with movement assistance, but relies entirely on the user to provide the coordination for movement (e.g., to select step length and time). The control approach also relies entirely on the user to initiate all movement. If the user is not constantly initiating movement, the user and exoskeleton will not move. Thus, the control approach relies on the user to be fundamentally engaged in the walking activity, and to provide appropriate coordination for it. The respective components of the control approach, and the state machine within which they operate, are described in the following sections.

### Control States and Notation

The exoskeleton controller is governed by a finite state machine consisting of six states, as illustrated in Fig. 3.1. Specifically, Fig. 3.1 depicts the exoskeleton configuration corresponding to each state, where the



affected leg is shown as a solid line, and the unaffected leg as a dashed line. The six states of the state machine are comprised of three primary configurations as follows: state 1 corresponds to the swing phase of the affected leg; state 2 corresponds to the double-support phase of walking; and state 3 corresponds to the swing phase of the unaffected leg. Each state is further comprised of two sub-states, as follows: sub-state 1a corresponds to the portion of swing in which the affected knee is in a state of flexion; sub-state 1b corresponds to the portion of swing in which the affected knee is in a state of extension; sub-state 2a corresponds to double-support following heel strike of the affected leg; sub-state 2b corresponds to double-support following heel strike of the unaffected leg; sub-state 3a corresponds to the portion of swing in which the unaffected knee is in a state of flexion; and sub-state 3b corresponds to the portion of swing in which the affected knee is in a state of extension. The sequence of states through which the controller would transition under normal walking conditions is illustrated in Fig. 3.1.

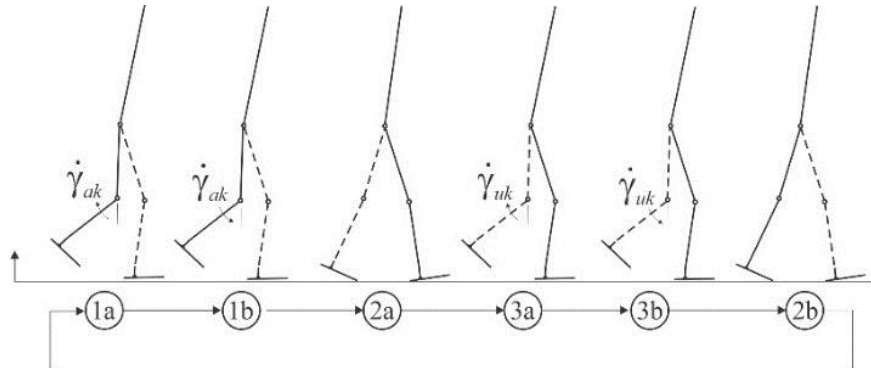

Figure 3.1 - Finite states corresponding to the assistive controller, where the affected leg is shown as a solid line and the unaffected leg as a dashed line. The three main states correspond to the 1) affected leg in swing, 2) double-support, and 3) unaffected leg in swing.

As per the subsequently described experimental implementation, the controller assumes an exoskeleton with four actuators, which provide sagittal plane torques at both the affected and unaffected hip and knee joints. The actuator torque vector corresponding to the four actuator torques can therefore be defined as:

$$\boldsymbol{\tau} = [\tau_{ak} \quad \tau_{ah} \quad \tau_{uk} \quad \tau_{uh}]^T \quad (1)$$

where  $\tau_{ak}$  and  $\tau_{ah}$  are the torque commands corresponding to the affected knee and hip joints, respectively, and  $\tau_{uk}$  and  $\tau_{uh}$  are the torque commands corresponding to the unaffected knee and hip joints, respectively. Since as previously mentioned the system is described by three configurational states, each with two sub-states, the torque vector within the  $i$ th state can be denoted by  $\boldsymbol{\tau}_i$ . For cases in which the control torque changes as a function of sub-state, the torque commands can be further indicated by  $\boldsymbol{\tau}_{ia}$  or  $\boldsymbol{\tau}_{ib}$ , corresponding to the appropriate sub-state. Within each state, the control torque may consist of the combination of multiple assistive torque components. If each assistive component of torque is identified by the subscript  $j$ , the composite control torque can be denoted by  $\boldsymbol{\tau}_{ij}$ . Given this notation, the control torques corresponding to the various assistive components are described below.

### Exoskeleton Gravity Compensation

A gravity compensation component of the controller is intended to remove the gravitational burden of the exoskeleton mass from the user, and is described by the following control law:

$$\boldsymbol{\tau}_{11} = g \begin{bmatrix} m_{es} l_{ces} \cos \theta_{as} \\ m_{et} l_{cet} \cos \theta_{at} + m_{es} l_{et} \cos \theta_{at} + m_{es} l_{ces} \cos \theta_{as} \\ m_{eh} l_{ceh} \cos \theta_{hat} + (m_{et} l_{cet} + m_{es} l_{et}) \cos \theta_{at} + m_{es} l_{ces} \cos \theta_{as} \dots \\ + ((m_{eh} + m_{et} + m_{es}) l_{et} + m_{et} (l_{et} - l_{cet})) \cos \theta_{ut} \\ m_{eh} l_{ceh} \cos \theta_{hat} + (m_{et} l_{cet} + m_{es} l_{et}) \cos \theta_{at} + m_{es} l_{ces} \cos \theta_{as} \end{bmatrix} \quad (2)$$

$$\boldsymbol{\tau}_{21} = g \begin{bmatrix} \frac{1}{2} m_{eh} l_{et} \cos \theta_{at} + m_{et} (l_{et} - l_{cet}) \cos \theta_{at} + \frac{1}{2} m_{eh} l_{ceh} \cos \theta_{hat} \\ \frac{1}{2} m_{eh} l_{ceh} \cos \theta_{hat} \\ \frac{1}{2} m_{eh} l_{et} \cos \theta_{ut} + m_{et} (l_{et} - l_{cet}) \cos \theta_{ut} + \frac{1}{2} m_{eh} l_{ceh} \cos \theta_{hat} \\ \frac{1}{2} m_{eh} l_{ceh} \cos \theta_{hat} \end{bmatrix} \quad (3)$$

$$\tau_{31} = g \begin{bmatrix} m_{eh} l_{ceh} \cos \theta_{hat} + (m_{et} l_{cet} + m_{es} l_{et}) \cos \theta_{ut} + m_{es} l_{ces} \cos \theta_{us} \dots \\ + ((m_{eh} + m_{et} + m_{es}) l_{et} + m_{et} (l_{et} - l_{cet})) \cos \theta_{at} \\ m_{eh} l_{ceh} \cos \theta_{hat} + (m_{et} l_{cet} + m_{es} l_{et}) \cos \theta_{ut} + m_{es} l_{ces} \cos \theta_{us} \\ m_{es} l_{ces} \cos \theta_{us} \\ (m_{et} l_{cet} + m_{es} l_{et}) \cos \theta_{ut} + m_{es} l_{ces} \cos \theta_{us} \end{bmatrix} \quad (4)$$

where  $\theta_{as}$  and  $\theta_{at}$  are the angles with respect to the vertical of the affected shank and thigh segments, respectively, and  $\theta_{us}$  and  $\theta_{ut}$  are the angles with respect to the vertical of the unaffected shank and thigh segments, respectively, as identified in Fig. 3.2;  $m_{eh}$ ,  $m_{et}$ , and  $m_{es}$  are the respective masses of the exoskeleton hip, thigh and shank segments;  $l_{ceh}$ ,  $l_{cet}$ , and  $l_{ces}$  are the respective distances of the center of mass of the hip, thigh and shank segments of the exoskeleton from the hip, hip, and knee joints, respectively;  $l_{et}$  is the length of the exoskeleton thigh segment; and  $g$  is the magnitude of the gravitational acceleration. Note that the mass of the hip segment is shared equally between the two legs in the double support phases of gait (i.e., state 2). Note also that the gravity compensation described by this control law assumes that movement occurs principally in the sagittal plane (i.e., neglects out-of-plane movements). Finally, note that in the single-support phases (states 1 and 3), the contralateral limb must provide reactive torques, since the gravitational loads are ultimately reacted through the support foot by the ground. Finally, note that this component of the control law does not vary with sub-state.

### Partial Compensation of Swing-Leg Weight

Hemiparetic patients frequently exhibit reduced muscle strength in the affected limb, which can impair the ability to achieve healthy joint excursions, and therefore clearance between the foot and ground during the swing phase of gait. In order to provide movement assistance without dictating joint trajectories, one of the components of the exoskeleton controller is a partial limb weight compensation of the affected leg during the swing phase of gait. Since the weight of the limb assists movement when movement of the limb is in

the direction of gravity (i.e. when gravity is performing positive work on the limb), active compensation during these phases could potentially increase the energetic output required by the user. As such, the partial limb weight compensation component is only exerted by the controller when the control torque works against the energy gradient (i.e., when the exoskeleton joint is generating power), and is zeroed when the control torque is along the energy gradient (i.e., when the exoskeleton joint absorbs power). As such, the partial limb weight compensation controller is described by:

$$\boldsymbol{\tau}_{12} = r \begin{bmatrix} \tau_{ah} & \tau_{ah} & \tau_{ak} & \tau_{ah} \end{bmatrix}^T \quad (5)$$

$$\tau_{ak} = \begin{cases} m_s l_{cs} \cos \theta_{as} & \text{if } (m_s l_{cs} \cos \theta_{as}) \dot{\gamma}_{ak} > 0 \\ 0 & \text{otherwise} \end{cases} \quad (6)$$

$$\tau_{ah} = \begin{cases} (m_t l_{ct} + m_s l_t) \cos \theta_{at} \dots & \text{if } ((m_t l_{ct} + m_s l_t) \cos \theta_{at} \dots \\ \quad + m_s l_{cs} \cos \theta_{as} & + m_s l_{cs} \cos \theta_{as}) \dot{\gamma}_{ah} > 0 \\ 0 & \text{otherwise} \end{cases} \quad (7)$$

$$\boldsymbol{\tau}_{22} = \boldsymbol{\tau}_{32} = \begin{bmatrix} 0 & 0 & 0 & 0 \end{bmatrix}^T \quad (8)$$

where  $\gamma_{ak}$  and  $\gamma_{ah}$  are the joint angles of the affected knee and hip joints, respectively, as identified in Fig. 3.2;  $m_t$ , and  $m_s$  are the respective masses of the user's thigh and shank segments;  $l_t$  is the length of the thigh segment (note that this is the same value as  $l_{ct}$ );  $l_{ct}$ , and  $l_{cs}$  are the respective distances of the center of mass of the user's thigh and shank segments from the hip and knee joints, respectively; and  $r \in [0,1)$  is a user-selectable gain that determines the extent of limb weight compensation during the affected-limb swing phase. Note that the authors chose not to provide the corresponding reactive torques on the stance side of

the exoskeleton, since it was assumed that these loads were most appropriately reacted by the user's unaffected leg (i.e., they would be reacted by the unaffected leg in the case that the affected leg was not in a weakened state).

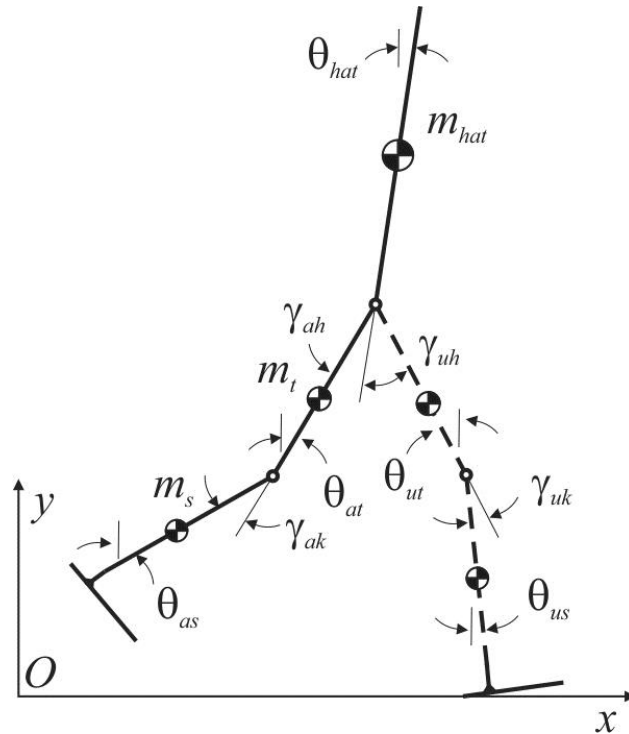

Figure 3.2 - Configuration parameters for assistive control approach.

### Feedforward Movement Assistance during Swing

Reducing the apparent weight of the swing limb reduces the burden of movement, while maintaining an energetically passive character of human/exoskeleton interaction. Such assistance, however, may not be sufficient to achieve suitable swing-phase motion at the hip and knee joints, depending on the level of impairment in the affected limb, and also on the level of spasticity or tone present in the limb. Insufficient swing-phase motion at the hip and knee joints can consequently result in foot dragging during mid-swing, reduced step length, or inability to fully extend the knee prior to heel strike. In order to provide additional assistance without dictating joint trajectories, a control component is available to provide hip or knee joint

torque pulses at the initiation of swing, and/or during mid-swing when the knee changes its direction of rotation from flexion to extension. Specifically, in order to avoid providing trajectory-based assistance, the controller allows the user to initiate a given movement, then supplements that movement with a brief torque pulse at the respective joint, as follows:

$$\boldsymbol{\tau}_{1a3} = [\tau_{ak} \quad \tau_{ah} \quad 0 \quad 0]^T \quad (9)$$

$$\tau_{ak} = \begin{cases} \frac{P_{kf}}{2} \left( 1 + \sin\left(\frac{2\pi}{T_{kf}} t_a - \frac{\pi}{2}\right) \right) & \text{if } 0 < t_a < T_{kf} \\ 0 & \text{otherwise} \end{cases} \quad (10)$$

$$\tau_{ah} = \begin{cases} \frac{P_{hf}}{2} \left( 1 + \sin\left(\frac{2\pi}{T_{hf}} t_a - \frac{\pi}{2}\right) \right) & \text{if } 0 < t_a < T_{hf} \\ 0 & \text{otherwise} \end{cases} \quad (11)$$

$$\boldsymbol{\tau}_{1b3} = [\tau_{ak} \quad 0 \quad 0 \quad 0]^T \quad (12)$$

$$\tau_{ak} = \begin{cases} \frac{P_{ke}}{2} \left( 1 + \sin\left(\frac{2\pi}{T_{ke}} t_b - \frac{\pi}{2}\right) \right) & \text{if } 0 < t_b < T_{ke} \\ 0 & \text{otherwise} \end{cases} \quad (13)$$

$$\boldsymbol{\tau}_{23} = \boldsymbol{\tau}_{33} = [0 \quad 0 \quad 0 \quad 0]^T \quad (14)$$

where  $P_{kf}$  and  $T_{kf}$  are the torque pulse amplitude and duration, respectively, for the knee flexion torque pulse;  $P_{hf}$  and  $T_{hf}$  are the torque pulse amplitude and duration, respectively, for the hip flexion torque pulse;  $P_{ke}$  and  $T_{ke}$  are the torque pulse amplitude and duration, respectively, for the knee extension torque pulse; and  $t_a$  and  $t_b$  are the length of time since the controller entered sub-states 1a and 1b, respectively. Note that the amplitude and duration of each torque pulse are selected and adjusted as needed by a particular patient.

### Knee Joint Stability Reinforcement during Stance

The affected stance limb is often subject to instability, particularly at the knee joint, which can result in instability in flexion or hyperextension. In order to prevent such instability (i.e., buckling), the controller provides “soft” stops in flexion and hyperextension during single-support at the stance knee of the affected leg, which consist of simulated spring and damper couples as follows:

$$\boldsymbol{\tau}_{14} = \boldsymbol{\tau}_{34} = [0 \quad 0 \quad 0 \quad 0]^T \quad (15)$$

$$\boldsymbol{\tau}_{24} = [\tau_{ak} \quad 0 \quad 0 \quad 0]^T \quad (16)$$

$$\tau_{ak} = \begin{cases} k(\gamma_{ak} - \gamma_{fss}) + b\dot{\gamma}_{ak} & \text{if } (\gamma_{ak} > \gamma_{fss}) \wedge (\tau_{ak} > 0) \\ -k(\gamma_{ak} - \gamma_{ess}) - b\dot{\gamma}_{ak} & \text{if } (\gamma_{ak} < \gamma_{ess}) \wedge (\tau_{ak} < 0) \\ 0 & \text{otherwise} \end{cases} \quad (17)$$

where  $k$  is the stiffness of the soft stop;  $b$  is the damping associated with the soft stop; and  $\gamma_{fss}$  and  $\gamma_{ess}$  are the angular positions of the flexion and hyperextension soft stops, respectively, at the knee. The composite assistive controller, which provides the movement assistance components as described individually above,

is collectively described within each finite state  $i$  by summing the torque components enumerated in equations (1) through (17):

$$\tau_i = \sum_{j=1}^4 \tau_{ij} \quad (18)$$

Recall that the subscript  $i$  in (18) represents the  $i^{\text{th}}$  state of the state machine, where  $i$  represents one of 6 states (1a/b, 2a/b, or 3a/b) as illustrated in Fig. 3.1 and discussed in the following section.

### Structure of the State Machine

The switching conditions that describe movement between the finite states of the state machine are shown in Fig. 3.3. In particular, switching between sub-states 1a and 1b, or 3a and 3b, is based on a change in the sign of the knee angular velocity in the affected and unaffected swing leg, respectively, as measured by angular encoders at the respective knee joints. The controller switches from single-support to double-support states via detection of heel strike of the respective swing leg, which can be detected when the acceleration aligned with the respective leg, as measured by an accelerometer, exceeds a given threshold. Finally, the controller switches from double-support to swing (i.e., out of 2a or 2b) when the angular velocity of the respective thigh, as measured by a gyroscope, exceeds a given threshold (i.e., the user initiates swing by accelerating the thigh forward, until it reaches a detectable angular velocity).



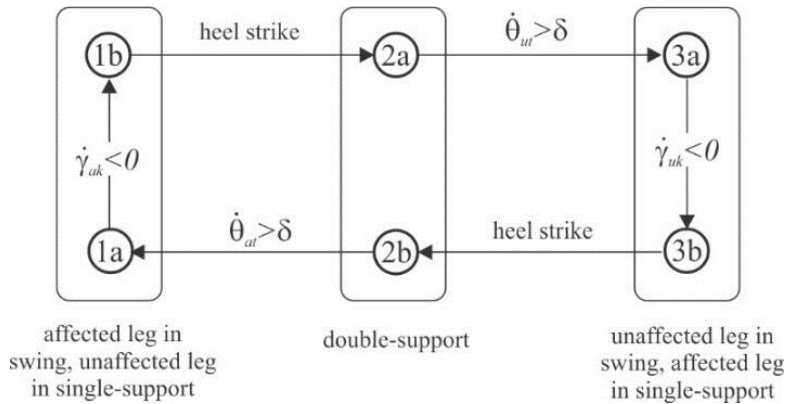

Figure 3.3- Finite state machine switching conditions corresponding to the assistive controller.

### Experimental Implementation and Preliminary Assessment

#### Exoskeleton Prototype

The previously described assistive control approach was implemented on the Vanderbilt lower limb exoskeleton, which is shown in Fig. 3.4. Design of the exoskeleton was previously described in the context of providing legged mobility for individuals with paraplegia [1, 10]. The exoskeleton incorporates four control actuators (brushless DC motors acting through speed reduction transmissions) that provide sagittal-plane torques at the right and left hip and knee joints (relative to the exoskeleton frame). The control actuators are capable of providing continuous torques at each joint of approximately 20 Nm, and peak torques of approximately 80 Nm for durations on the order of a few seconds (thermally limited). The exoskeleton is used with ankle foot orthoses (AFOs), which provide stability at the ankle joints and transfer the weight of the exoskeleton to the ground. Instrumentation (for measurement of configuration angles, Fig. 3.2, and of state machine switching conditions, Fig. 3.3) include absolute and incremental encoders at each joint, and one six-axis inertial measurement unit (IMU) in each thigh link (i.e., two total). The exoskeleton is powered by a 30 v, 120 W-hr lithium polymer battery with a mass of approximately 600 g. The total mass of the system, including the battery, is approximately 12 kg (26.5 lb).

## Preliminary Assessment Procedure

In order to provide a preliminary assessment of the efficacy of the exoskeleton controller, and in particular to assess the appropriateness and potential of the assistive controller to facilitate walking in individuals with lower limb hemiparesis following stroke, the authors implemented the assistive controller on the Vanderbilt exoskeleton, and conducted a preliminary evaluation on three human subjects with lower limb hemiparesis following stroke. Relevant information regarding each subject is summarized in Table I. Prior to conducting the preliminary evaluations, the exoskeleton was fit to each subject, and the assistive control parameters incorporated in equations (5), (10), (11), (13), and (17) were tuned according to each individual subject's needs, with the parameter tuning guided by a combination of physical therapist and subject input, such that once appropriately adjusted, the combined effort of the subject and exoskeleton achieved appropriate foot clearance during swing and knee stability during stance (as judged by the therapist). Specifically, the proportion of limb weight compensation  $r$  (eqn 5) was initialized at zero and iteratively incremented until appropriate hip flexion was achieved in swing. Note that a torque pulse at the hip in early swing, as given by  $P_{hf}$  and  $T_{hf}$  (eqn 11) could similarly be used to supplement hip flexion in swing, but was not employed for the assessments described here. The swing phase knee flexion torque pulse parameters  $P_{kf}$  and  $T_{kf}$  (eqn 10) were initialized at zero and iteratively incremented until appropriate knee flexion was achieved in early swing. Similarly, the swing phase knee extension pulse parameters  $P_{ke}$  and  $T_{ke}$  (eqn 13) were initialized at zero and iteratively incremented until appropriate knee extension was achieved in late swing. Finally, the stance knee soft stop locations  $\gamma_{fss}$  and  $\gamma_{ess}$  (eqn 17) were adjusted to provide a small range of unencumbered motion around a neutral angle of the knee during stance, prior to engaging the virtual soft stops. In this manner, each individual subject was required to provide knee stability during the stance phase of gait, with the exoskeleton providing support only when the knee travelled outside of this range. The angle of engagement of the soft stops were established based on the collective comfort level of the subject and physical therapist regarding an appropriate range of knee movement prior to engaging exoskeleton

support. In particular, two of the subjects were comfortable with an unencumbered range of motion between zero and 8 deg (flexion), while one subject (whose knee was particularly prone to instability) preferred a range between 2 and 6 deg flexion. Because the level of impairment varied between patients, parameter selection was largely informed by what the physical therapist believed was an appropriate level of device assistance for each individual patient, rather than by predetermined goals for gait performance. Note that the stiffness and damping of the soft stops were determined by the investigators when constructing the controller, and therefore were not among the tunable parameters. Also, gravity compensation parameters (eqns 2-4, 6-7) were measured or estimated, and as such were not among the tunable parameters. The values for all tunable parameters used in the experiments for each subject are given in Table II.

Once the assistive controller was suitably parameterized for each subject, a series of preliminary assessments were conducted. In particular, the preliminary assessments evaluated single-session gains in walking achieved by each subject in three separate therapy sessions. The nature of each session involved the subject walking overground with the exoskeleton (with assistive controller) for a period of approximately 30 min. Walking metrics were measured at the beginning of each session (i.e., prior to using the exoskeleton), and at the end of each session (i.e., immediately after doffing the exoskeleton). Three assessment metrics were utilized, including fast gait speed (FGS), step length asymmetry (SLA), and stride length (SL). Each session began with an approximately 5-minute warm-up which consisted of therapist-assisted overground walking (without the exoskeleton), during which each subject used his or her standard stability aids (in all cases this consisted of a quad-cane and unilateral AFO, see Table I). Following the warm-up period, each subject was allowed to rest if desired, after which the subject performed a ten meter walk test (10MWT). Subjects were instructed to “walk as fast as you safely can” over a 14 m distance, with the middle 10 m segment being timed to determine FGS.

Following this “pre-session 10MWT” the subject donned the exoskeleton, and walked overground in the exoskeleton, with a physical therapist providing balance assistance as needed (i.e., contact guard assist), as shown in Fig. 3.5. All subjects used a quad-cane when walking with the exoskeleton, as per their respective standard practices when walking without the exoskeleton. Subjects walked for approximately

20-30 minutes, in approximately 5 minute segments, resting as needed between walking segments. Figure 3.6 shows the hip and knee joint angles recorded on the paretic leg of subject 1 during a representative therapy session, averaged over ten consecutive strides, in addition to the hip and knee joint torque and power delivered by the exoskeleton. In the plots, positive angles indicate flexion and negative extension; positive torques indicate flexive, and negative extensive; and positive power indicates the exoskeleton is providing power to the subject, while negative power indicates the exoskeleton is dissipating power. This data provides some indication of the nature of interaction between the exoskeleton and the subject. Some of the control components as indicated in the plots include: a) flexive hip torque associated with gravity compensation; b) power dissipation associated with gravity compensation of the exoskeleton mass; c) flexive knee torque associated with feedforward flexion assistance in early swing; d) extensive knee torque associated with feedforward extension assistance in mid swing; and e) knee joint torque assistance associated with the knee joint stability component during stance (i.e., immediately following heel strike). Note that in general the exoskeleton generates and dissipates power at different periods of the gait cycle, but on average provides net power to the user (i.e., on average is assistive rather than resistive).

Following the period of walking in the exoskeleton, the subject doffed the exoskeleton and conducted a post-session 10MWT. Note that both the pre-session and post-session 10MWT were conducted without the exoskeleton. The full single-session protocol typically lasted approximately one hour. For each of the three subjects, the aforementioned single-session protocol was performed three times, each spaced three weeks apart to reduce the potential effects of carryover from previous sessions.



Figure 3.4 - Vanderbilt lower-limb exoskeleton.

TABLE 4  
Baseline Characteristics of Stroke Subjects

<b>Subject</b>	<b>1</b>	<b>2</b>	<b>3</b>
<b>Age (yrs)</b>	39	42	69
<b>Mos Post-Stroke</b>	3	10	17
<b>Affected Side</b>	Right	Left	Right
<b>Stability Aids Used</b>	Quad Cane, R AFO	Quad Cane, L AFO	Quad Cane, R AFO
<b>Baseline FGS (m/s)</b>	0.33	0.07	0.19
<b>Baseline SLA (%)</b>	29	115	27
<b>Baseline SL (cm)</b>	88.7	33.2	66.3



Figure 3.5 - Experimental subject walking in the exoskeleton during a training session. A physical therapist offers assistance as needed.

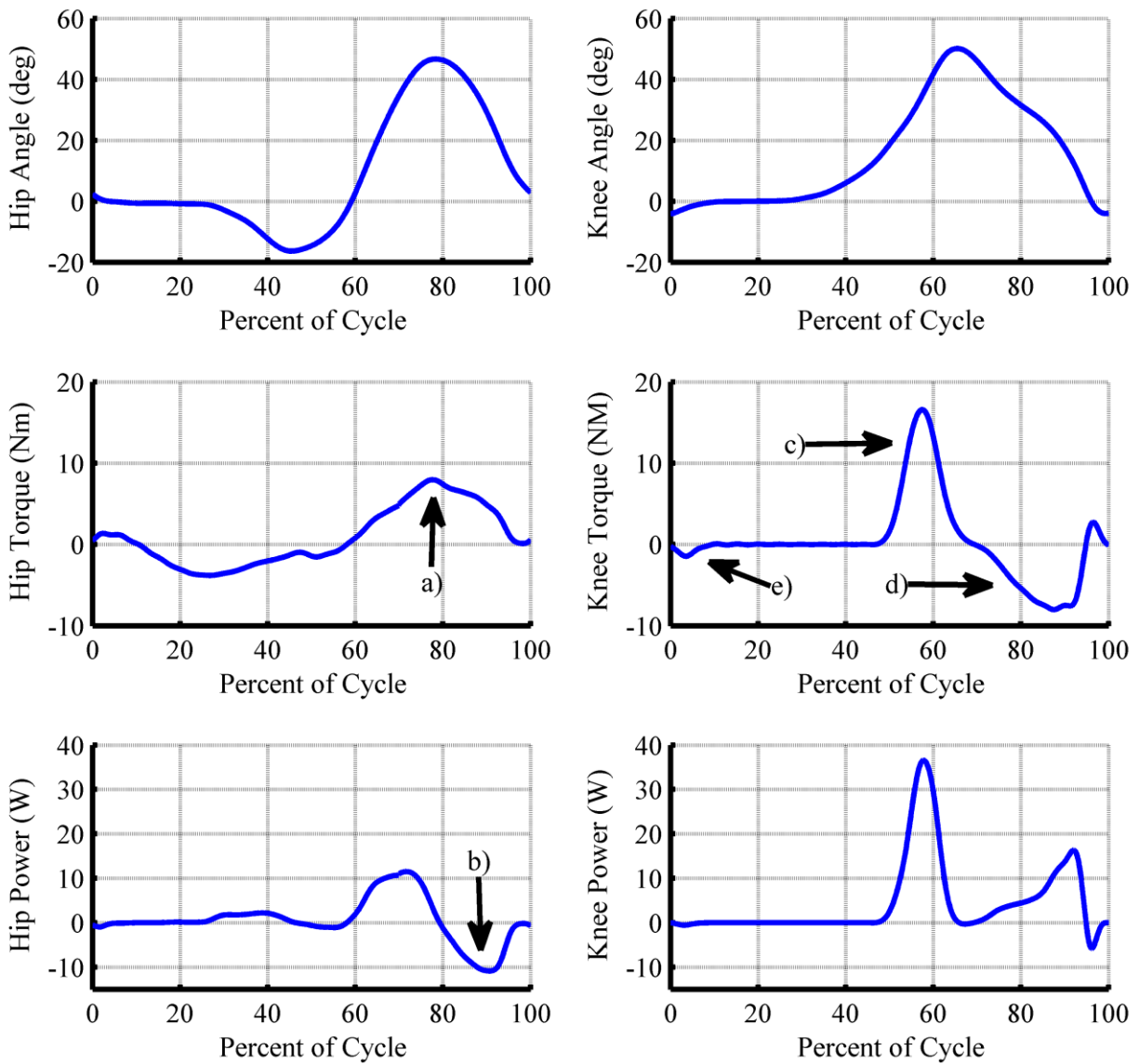

Figure 3.6 - Paretic leg hip and knee joint angles during exoskeleton walking from therapy session with subject 1, averaged over ten strides, and the associated torque and power at both joints imparted by the exoskeleton.

TABLE 5  
Tunable Control Parameters for Each Subject

Subject	1	2	3
r	0.20	.85	0.75
P <sub>kf</sub> (Nm)	17	0	17
T <sub>kf</sub> (s)	0.5	0.5	0.8
P <sub>hf</sub> (Nm)	0	0	0
T <sub>hf</sub> (s)	0.5	0.5	0.8
P <sub>ke</sub> (Nm)	10	5	12
T <sub>ke</sub> (s)	0.5	0.5	0.8
γ <sub>fss</sub> (deg)	8	6	8
γ <sub>ess</sub> (deg)	0	2	0

### Single-Session Results

Single-session effects were assessed by comparing the pre-session and post-session measures of FGS, SLA, and SL, with the difference presumably attributed to the session of overground exoskeleton walking. Note that FGS was calculated using a stopwatch as the average speed during the (middle 10 m portion of the) 10MWT, while SLA and SL were both measured via video post-processing of the recorded 10MWT. SLA is defined as:

$$SLA = 1 - \frac{x_u}{x_a} \tag{19}$$

where  $x_u$  is the average step length of the unaffected leg, and  $x_a$  is the average step length of the affected leg. This definition of SLA is slightly modified from other similar definitions present in the literature to evaluate step length asymmetry [28, 91]. Specifically, in the definition given in equation (19), a smaller value indicates increased symmetry, while a larger value indicates reduced symmetry. A perfectly symmetric gait would have an SLA score of 0, while an exact “step-to” gait (i.e. the unaffected limb is brought even with the affected limb during swing) would have an SLA value of 1. When comparing post-session to pre-session values, the percent change is indicated by the ratio of post and pre-session values of FGS and SL, while it is indicated by the difference between post and pre-session values of SLA, since SLA is already a ratio. Figure 3.7 shows the average improvement for each outcome measure across the three trials, grouped by subject. As is evident in Fig. 3.7, all subjects showed improvements in all outcome



measures in each of the trials. Figure 3.8 shows the single-session improvements for each outcome measure averaged across all subjects. Subjects demonstrated average improvements of 26%, 26%, and 30% in FGS, SLA, and SL, respectively.

### Conclusion

The authors present the implementation of an assistive controller for a lower limb exoskeleton, intended to facilitate recovery of walking function to persons with hemiparesis following stroke. The authors hypothesize that such recovery is facilitated by allowing the patient rather than the exoskeleton to provide movement coordination. As such, the objective of the control approach presented here is to provide to the patient movement assistance, without providing a desired joint angle path or trajectory. Accordingly, the authors developed and describe here a controller that provides walking assistance to the user, without dictating the spatiotemporal nature of a given movement, such that the user is required to provide the coordination of movement. In order to provide a preliminary assessment of efficacy, the authors implemented the controller on an exoskeleton prototype, and studied single-session improvements in walking in three subjects with lower limb hemiparesis following stroke. All subjects showed substantial improvement in three walking metrics in all sessions, indicating that the assistive control approach may have promise with respect to facilitating walking recovery. Future studies with a larger number of subjects and with longer periods of dosing will be required to fully assess the efficacy of such a system in providing recovery of walking following stroke.

### Single-session Improvements

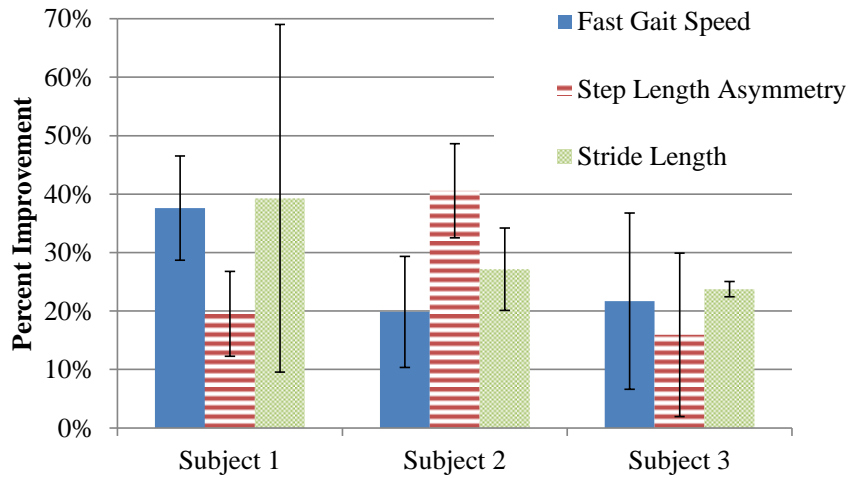

Figure 3.7 - Average single-session gains across all sessions for each measure grouped by subject. Error bars indicate plus/minus one standard deviation.

### Average Single-session Improvements

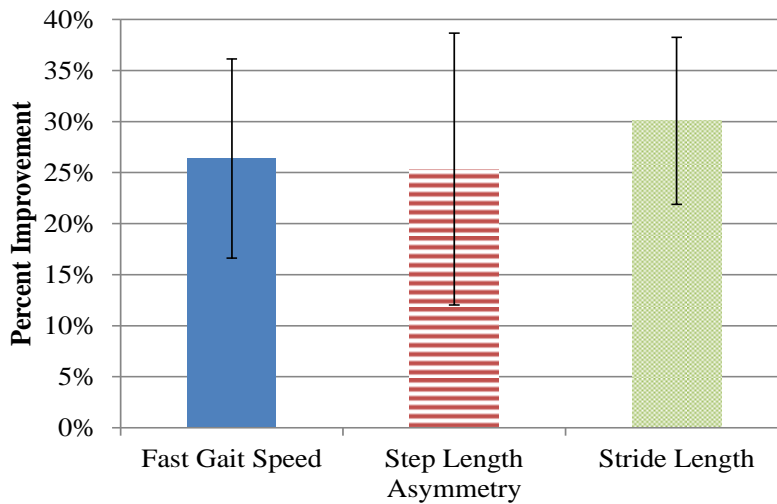

Figure 3.8 - Average single-session gains for each outcome measure averaged for all subjects and all sessions. Error bars indicate plus/minus one standard deviation.

## ADDENDUM

The preliminary study reported in Manuscript III demonstrated first and foremost that a non-trajectory based controller was feasible. The study also served to demonstrate that the developed NTB controller was capable of providing assistance to subjects with hemiparesis resulting from stroke. While the focus of Manuscript III is on the resulting changes to the subject's gait parameters, it should be noted that there had been no previous evidence to promote these baseline assumptions, and as such, assisting three subjects with hemiparesis in gait training with the NTB controller was in and of itself an accomplishment. As reported, the improvements to the subjects' gait parameters were also significant. However, this pilot study left several questions unanswered. First, was the NTB controller producing functional improvements in the subject's gait parameters which matched, exceeded, or fell short of the improvements produced by existing trajectory-based controllers? Single-session gains are not typically used as a metric for functional gait improvement as the long-term retention of these improvements is of critical importance. As such, the literature does not offer data which would permit comparison between the single-session gains observed when using the NTB controller and single-session gains produced by other RAGT systems. Second, were the exoskeleton and controller actually impacting the observed single-session gains? Because no control experiments without exoskeleton assistance were performed it was possible that the gains were merely due to practicing overground gait with a PT present for support. Finally, would these gains be maintained over time? The first and second questions motivated the experiment reported in Manuscript IV. The final question remains to be answered. The addendum to Manuscript IV in Chapter V discusses some evidence which was collected which suggests that subjects with hemiparesis do retain a portion of the gains made in practicing gait with the NTB controller.

## CHAPTER V

### COMPARISON OF NON-TRAJECTORY BASED AND TRAJECTORY BASED CONTROL

Conducting a large-scale randomized controlled trial (RCT) to determine the efficacy of a robotically-assisted gait trainer (RAGT) in restoring gait is a significant undertaking that requires substantial time, effort, and funding resources. The number of subjects required ranges significantly, but evaluations of RAGT systems typically involve somewhere between 50 and 200 patients to be divided into the experimental and control groups (based on recent RAGT RCT studies [49-51]). These subjects participate in gait training somewhere from three to five times weekly for a duration of up to 12 weeks, requiring thousands of man-hours from the patients as well as the physical therapists (PTs) performing the training. Monetary considerations alone are substantial with the total costs of such a study potentially exceeding one million dollars per month [92]. Further, if the experimental group forgoes additional therapy during the acute phases of stroke, study participants could potentially be left with increased impairment levels as the result of training with an inferior intervention.

With these deterrents to performing an RCT, it is necessary and responsible to conduct a considerable amount of preliminary work to establish an RAGT's efficacy before pursuing a large-scale trial. The work reported in Manuscript III suggested that the non-trajectory based (NTB) controller was capable of improving the fast gait speed, stride length, and step-length asymmetry of patients with hemiparesis. However the results did not clearly demonstrate that the NTB controller was superior to a trajectory-based (TB) controller implemented on an overground exoskeleton, or to conventional overground therapy (CT) performed by skilled PTs. The goal of the work presented in Manuscript IV was to demonstrate that the NTB controller was capable of producing greater gains in gait parameters when compared to gains made with a TB controller or CT intervention. The manuscript has been submitted for publication in the *IEEE Transactions on Neural Systems and Rehabilitation Engineering*.

# MANUSCRIPT IV: A PRELIMINARY CROSSOVER STUDY COMPARING THE EFFICACY OF TRAJECTORY-BASED AND NON-TRAJECTORY BASED CONTROL IN A LOWER-LIMB EXOSKELETON

## Abstract

This paper presents a pilot study that explicitly investigates the relative efficacy of using a trajectory versus a non-trajectory based control strategy for the control of a lower-limb exoskeleton, with respect to facilitating gait recovery in individuals with lower limb hemiparesis following stroke. The authors describe two control strategies for a lower-limb exoskeleton intended to aid gait rehabilitation in individuals with lower-extremity hemiparesis after stroke. One is a non-trajectory-based control approach, similar to one the authors have presented previously, and the other is a trajectory-based controller. Following the descriptions of these controllers, the authors present the results of a preliminary crossover study intended to assess the efficacy of these control approaches in facilitating gait recovery following stroke. In the study, both controllers were implemented on a lower limb exoskeleton, and tested on three subjects with hemiparesis following stroke. In a series of six sessions, each subject participated in overground gait training with each controller for two sessions, and completed an additional two sessions of overground gait training without the exoskeleton. Data collected during 10 meter walk tests prior to and following each gait training session were used to assess the relative impact of each session on each subject's gait. Results of these studies indicate that exoskeleton training with the non-trajectory-based controller was significantly more effective in providing (single-session) recovery gains than either the exoskeleton with trajectory-based controller, or than overground gait training without the exoskeleton.

## Introduction

With an estimated 6.6 million people in the United States having survived a cerebrovascular accident (CVA) and an estimated 610,000 first-incident CVAs occurring each year, CVA is one of the leading causes of chronic disability in the United States [93]. Restoration of gait functionality is typically a high priority

in the rehabilitation of patients with lower-limb hemiparesis [15, 52], which has motivated the development of a number of robotically-assisted gait-training devices, particularly in recent years. Although results vary in the highly-heterogeneous population of stroke patients, a recent survey of evidence indicates that electromechanically-assisted rehabilitation interventions on average improve the likelihood that a patient will recover the ability to ambulate independently in a meta-analysis of numerous devices [66]. Many control approaches have been proposed and described for the control of these robotically-assisted devices [39-41, 46, 47, 89, 94-98]. These control strategies can be roughly categorized as belonging to either a trajectory-based controlled or non-trajectory-based type. The former dictates the spatiotemporal nature of joint movement, while the latter does not. Examples of the latter include force tunnels around the desired trajectory [40, 41, 47], teach-and-replay impedance based control strategies to generate subject-specific trajectories [37], and model-based strategies to target specific portions of the gait cycle [38, 39].

A trajectory-based control approach in essence provides full coordination and effort associated with movement. A trajectory control approach can be implemented with a number of standard approaches (i.e., within a high-gain PD control loop), and can also offer functional advantages relative to a non-trajectory control approach, such as the ability to consistently reproduce healthy gait kinematics, the ability to provide full movement assistance, and the ability to provide early therapy to subjects who may otherwise be non-ambulatory. Despite these potential advantages, the authors hypothesize that in the case of a trajectory-based approach, since the machine both coordinates and generates movement, the patient may be inclined to assume a passive role within it. It is well-known that increased engagement of the patient results in improved outcomes [68, 70], and therefore recovery is more likely if the machine promotes active rather than passive engagement. Thus, despite the advantages of a trajectory-based controller, the authors hypothesize that a non-trajectory-based control approach would place increased responsibility for coordination and movement on the patient, and would therefore require greater engagement, and thus presumably result in improved functional outcomes.

Based on this hypothesis, the authors developed in prior work [99] a non-trajectory-based assistive exoskeleton controller that provided walking assistance without dictating the spatiotemporal nature of joint

movement, based on the hypothesis that a trajectory-based control approach would interfere with, and therefore be less well-suited to, gait recovery. The non-trajectory-based control approach was shown in preliminary studies to provide promising single-session improvements in the gait of stroke-affected patients. That work, however, did not explicitly test the hypothesis regarding the relative efficacy of a trajectory versus a non-trajectory based exoskeleton control strategy. Specifically, would the improvements have been different if the lower limb exoskeleton had employed a trajectory-based controller? Even more so, were the improvements due to the assistance of the exoskeleton, or would gait training sessions of similar duration without an exoskeleton have resulted in similar outcomes? The intent of the work described here is to more explicitly investigate these questions, within the statistical limitations of a pilot study.

In order to address these questions, and specifically to test the hypothesis that a non-trajectory-based exoskeleton control approach is better suited to facilitating recovery relative to a trajectory-based approach, the authors developed a trajectory-based control approach for a lower-limb exoskeleton, implemented both control approaches on the Exoskeleton prototype, and employed the exoskeleton and both versions of controller in a pilot clinical study involving three subjects with hemiparesis resulting from stroke. In addition to therapy sessions with the trajectory based and non-trajectory based controllers, subjects participated in therapy sessions in which they did not use the exoskeleton, and were instead given conventional overground gait therapy by an experienced physical therapist (PT). Sessions performed without the exoskeleton acted as a control to determine whether the use of the robot was beneficial to the subjects, relative to a conventional gait therapy session. Each subject participated in two therapy sessions under each therapy condition (trajectory based exoskeleton therapy, non-trajectory based exoskeleton therapy, and the control condition) which were presented to each subject in a semi-randomized order to minimize any ordering effects. Single-session gains were measured during 10 meter walk tests (10MWT) performed prior to and immediately following each therapy session (all assessments were performed without wearing the exoskeleton). This paper describes each of the three therapy conditions, the experimental procedure, and the results of these pilot studies. A discussion section follows which analyzes the results and discusses future work.

## Controller Descriptions

Both the non-trajectory-based (NTB) and trajectory-based (TB) controllers operate using a finite state machine which divides the gait cycle into discrete states and dictates behavior based on state. The NTB controller has been described in detail previously by the authors [99]. For completeness, the salient features of the controller are briefly described below. The TB controller was developed to provide freedom of the unaffected leg, while still enforcing trajectory-based control of the affected-side hip and knee joints in the sagittal plane. A complete description of the TB controller is provided below.

### The Non-Trajectory Based Controller

The NTB controller consists of four assistive components, consisting of: 1) exoskeleton gravity compensation, 2) partial compensation of swing leg weight, 3) feedforward movement assistance in swing, and 4) knee joint stability reinforcement during stance. None of these assistive components enforce a trajectory at any point in the gait cycle (i.e., none involve a time-dependence). Note that while exoskeleton gravity compensation is provided to both legs, the latter three assistive components are imposed exclusively on the affected leg. As such, the torque components applied to the unaffected leg are restricted to: 1) gravity compensation for the weight of the exoskeleton, and 2) reactive torques that transfer the assistive torques employed on the affected leg during swing phase to ground. The components of the NTB controller are briefly described below. See [99] for a more detailed description of the NTB controller.

### Finite State Control Structure

A finite state machine (FSM) dictates the sequencing of the assistive components (as a function of state) by dividing the gait cycle into three primary states and six sub-states. States 1, 2, and 3 correspond to the swing-phase of the affected leg, the double-support phase, and the swing-phase of the unaffected leg respectively. Substate 1a comprises the portion of the affected-leg swing phase in which the knee is flexing.



Substate 1b comprises the portion of the affected-leg swing phase in which the knee is extending. Substate 2a comprises the double support phase following the heelstrike of the affected leg. Substate 2b comprises the double support phase following the heelstrike of the unaffected leg. Substate 3a comprises the portion of the unaffected-leg swing phase in which the knee is flexing. Substate 3b comprises the portion of the unaffected-leg swing phase in which the knee is extending. The sequence of states, and the exoskeleton's configuration in each state is depicted in Fig. 4.1. Fig. 4.2 depicts the switching conditions for the state machine of each of the two controllers. For the NTB controller, Fig. 4.2a, transitions between double support and swing phases (i.e. the transition from states 2a to 3a and the transition from 2b to 1a) occur when the angular velocity of the swing-leg exoskeleton-link, as measured by an onboard inertial measurement unit (IMU), exceeds a given threshold. Transitions between the substates of states 1 and 3 (1a to 1b and 3a to 3b) occur when the velocity of the knee joint changes from a positive (flexing) to a negative (extending) value, as measured by angular encoders at the knee joint. Transitions between swing states and double support states (3b to 2b and 1b to 2a) occur when heel strike is detected in the swing leg, which is detected when the acceleration along the thigh-link of the exoskeleton exceeds a given threshold, as measured by an accelerometer.

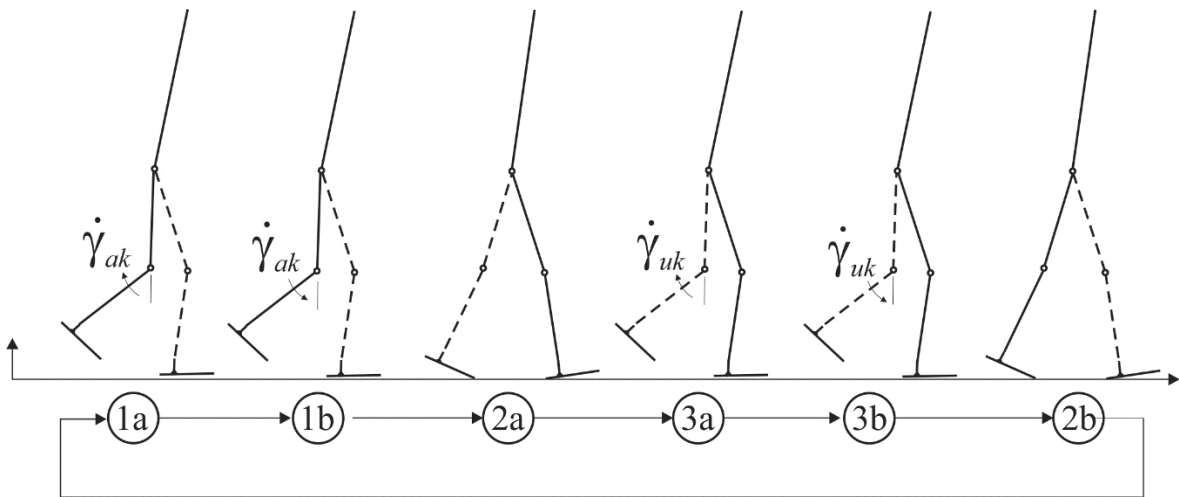

Figure 4.1. Sequence of states used in the finite state machine and the configuration of the user in each state. The dashed line indicates the unaffected limb while the solid line indicates the affected limb.

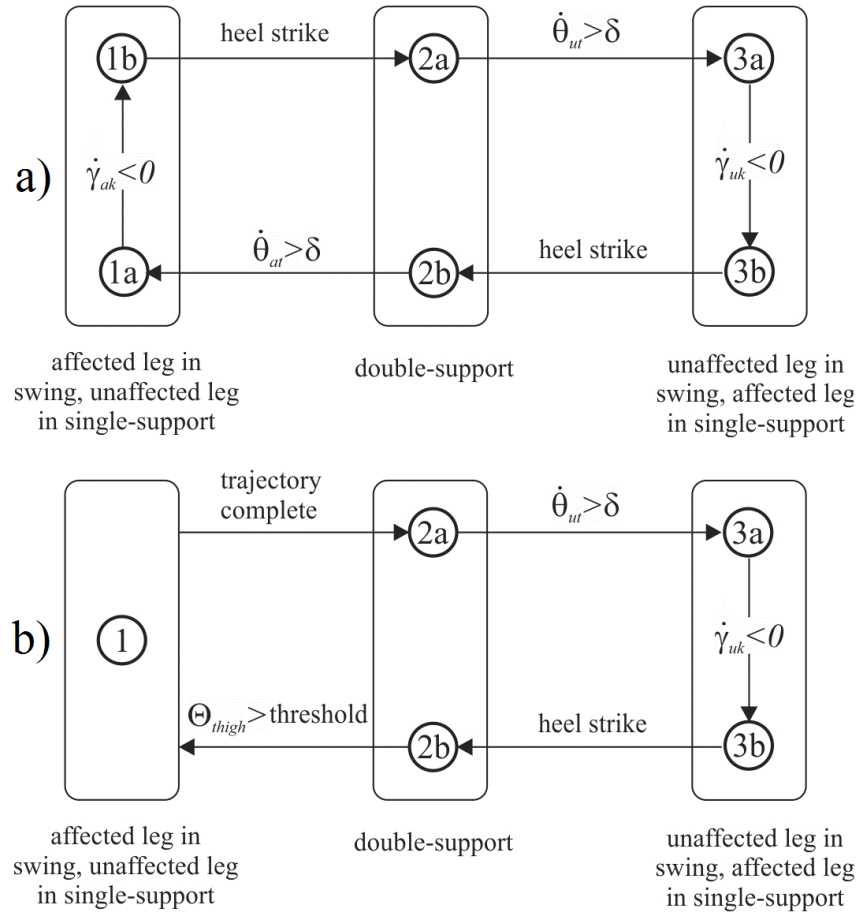

Figure 4.2. State-machine switching conditions for both a.) the non-trajectory based controller and b.) the trajectory based controller

### Control Components Imposed on Unaffected Leg

The unaffected leg is assisted exclusively with exoskeleton gravity compensation (i.e., intended to negate the weight of the exoskeleton), which is active only during state 3 (unaffected leg swing phase). No assistive components are actively imposed on the unaffected leg in states 1 (unaffected leg stance) or 2 (double-support).

## Control Components Imposed on Affected Leg

In addition to exoskeleton gravity compensation (intended to negate the weight of the exoskeleton), three other control components assist the affected leg, as described below.

### Partial Compensation of Swing Leg Weight

Weakness in the affected limb is a common symptom of hemiparesis. In order to reduce the gravitational burden of swing and promote increased joint excursion without driving the joints along a predefined joint trajectory, the NTB controller provides compensation for a (user-selectable) portion of the swing-leg mass during the affected-leg swing phase of gait (states 1a and 1b). However, because the weight of the limb aids movement as the leg moves in the direction of gravity, reducing limb weight when with the gravitational energy gradient would increase the effort required of the patient to return the foot to the ground. As such, this assistive component is active only when the motion of the leg is opposite the direction of gravity (i.e. when the joint is producing positive work), and is disabled otherwise. The portion of the limb weight to be balanced is variable and may be adjusted between 0% and 100% of the limb's estimated mass. Because the portion of limb weight to be balanced is never set to compensate more than 100% of the estimated torque generated by the limb's weight, this component reduces joint torques while remaining energetically passive.

### Feedforward Movement Assistance during Swing

In cases of extreme weakness, tone, or spasticity in the muscles of the paretic limb, the NTB controller can provide additional assistive torque pulses at each joint to either help initiate and/or terminate swing (i.e., at the beginning of substates 1a and 1b, respectively). The amplitude and duration of each torque pulse may be adjusted individually for each joint and each phase.

## Knee Joint Stability Reinforcement during Stance

While most assistive components of torque assist with the swing phase of gait, the NTB controller also provides an assistive component to guard against instability in the affected-limb knee during stance phase by providing emulated spring-damper couples which create “soft” stops when the knee joint flexes or extends beyond an adjustable set flexion and extension limits. This component is active during the affected-leg, single-support phase of stance (substates 3a and 3b). The flexion and extension limits, as well as the spring coefficient and damper coefficient, are PT adjustable and are set based on the needs of the patient.

### The Trajectory Based Controller

The TB controller was developed in order to test the relative value and appropriateness of using an NTB versus a TB controller to facilitate walking recovery in overground walking with a lower limb exoskeleton following stroke. Like the NTB controller, all assistive torques are directed at the affected leg, while the torque components applied to the unaffected leg are restricted to: 1) gravity compensation for the weight of the exoskeleton, and 2) reactive torques that transfer the assistive torques employed on the affected leg during swing phase to ground.

### Finite State Control Structure

The TB controller employs a similar FSM as used in the NTB controller, although 1) swing phase consists of one rather than two states and 2) the conditions for entering and exiting swing phase are somewhat different. The TB FSM is shown in Fig. 4.2b. Regarding the former, while the NTB controller divides swing into a knee flexion and knee extension portion in order to appropriately time assistive torque pulses, the TB controller uses a single trajectory for swing, and therefore need not separate it into two states. With regard to the latter, while the NTB FSM enters swing based on thigh angular velocity in late stance, the TB FSM enters swing phase based on the thigh angle (with respect to gravity). Since the joints follow predetermined

trajectories in the TB controller, switching based on angle provides better velocity matching between the initial knee and hip angular velocities, and those of the predetermined desired trajectories (all of which start at rest).

### Control Components Imposed on Unaffected Leg

As with the NTB controller, the unaffected leg is assisted exclusively with exoskeleton gravity compensation (i.e., intended to negate the weight of the exoskeleton), which is active only during state 3 (unaffected leg swing phase). No assistive components are actively imposed on the unaffected leg in states 1 (unaffected leg stance) or 2 (double-support).

### Control Components Imposed on Affected Leg

During affected-leg swing and stance (i.e., states 1 and 3, respectively), the TB controller incorporates high-gain proportional-derivative (PD) control loops to control the angular position of the affected-side hip and knee joints. The control loops and joint angle trajectories employed in this trajectory-based controller are the same as the ones reported in [1]. The trajectories are parametric, such that 1) the initial angular position of the hip and knee, 2) the peak angular position of the hip and knee, and 3) the step time can all be adjusted by the PT to suit the needs of a given patient. During the double-support phase (state 2), the knee and hip joints of the affected leg are stabilized with spring and damper couples, as reported in [1].

## Methods

### Exoskeleton Prototype

The previously described NTB and TB controllers were implemented on a lower-limb exoskeleton prototype, shown in Fig. 4.3. The prototype utilizes a commercially-available lower-limb exoskeleton (Indego Exoskeleton, Parker Hannifin Corp) as a hardware platform, and replaces the commercial version

of the software with the NTB and TB controllers described here. The Indego exoskeleton hardware platform incorporates 4 motors for powered movement of bilateral hip and knee joints in the sagittal plane, in addition to built-in ankle-foot-orthoses (AFOs) at both ankle joints to provide ankle stability and transfer the weight of the exoskeleton to the ground. Onboard electronic sensors include absolute and incremental encoders at each joint and a six-axis inertial measurement unit (IMU) in the thigh link of each leg. The total mass of the exoskeleton including the battery is 12 kg (26 lbs). A more detailed description of the hardware platform is provided in [6].



Figure 4.3. The Indego Exoskeleton

#### Preliminary Crossover Study

Initial experiments characterizing single-session effects of using the exoskeleton with the NTB controller indicated that subjects were able to walk overground with improved gait speed, stride length, and step-length asymmetry after 20 to 30 minutes of exoskeleton-assisted overground gait therapy. However, that study did not explicitly demonstrate that these gains were the result of the exoskeleton-assisted therapy,

since more conventional therapy (i.e., without an exoskeleton) could have produced a similar result. Further, while the authors hypothesized that a NTB controller would better facilitate walking recovery relative to a TB controller, the pilot study did not incorporate a TB controller to provide a basis for comparison. As such, the previous study offered promising results, but without controlled cases (i.e., context) with which to interpret the results.

In order to investigate the hypothesis that a NTB controller might better facilitate recovery of walking in hemiparetic patients, both the TB controller and the NTB controller were implemented in the exoskeleton prototype, and a preliminary crossover study was performed to evaluate the single-session gains made by three subjects with lower-limb hemiparesis, comparing the exoskeleton intervention with NTB controller to the exoskeleton intervention to TB controller, and to a similar period of overground walking, without the use of an exoskeleton.

### Study Design

Each patient participated in a total of six therapy sessions; two sessions in the exoskeleton using the NTB controller, two sessions in the exoskeleton using the trajectory based controller, and two sessions in which the patient did not interact with the exoskeleton and instead practiced overground gait with PT assistance. The order in which these three conditions (exoskeleton with NTB controller, exoskeleton with TB controller, and control condition without exoskeleton assistance) were presented was randomized to eliminate ordering effects in the data. Subjects participated in the same therapy condition two weeks in a row to minimize confusion and learning time when switching between conditions. The order of conditions for each patient is presented in Table II. Each session was performed one week apart to allow time for washout between sessions.

Before beginning therapy sessions, subjects were fitted for the exoskeleton and had their baseline gait characteristics evaluated. Table I summarizes the baseline gait characteristics of the participants prior to beginning therapy sessions. Each therapy session lasted two hours and was structured slightly differently

depending on the therapy condition used. The session structure for each case is described below.

TABLE 6  
Baseline Characteristics of Stroke Subjects

Subject	1	2	3
Age (years)	50	61	61
Months Post-Stroke	7	12	22
Affected Side	Left	Right	Right
Stability Aids Used	Quad Cane L AFO	Cane	Quad Cane R AFO
Baseline FGS (m/s)	0.49	0.36	0.30
Baseline SL (cm)	98	81	74

TABLE 7  
Therapy Condition Order for Each Subject

Subject	Therapy Condition		
	Session 1-2	Session 3-4	Session 5-6
1	Trajectory Based	Non- Trajectory Based	Control
2	Non- Trajectory Based	Control	Trajectory Based
3	Control	Non- Trajectory Based	Trajectory Based

#### Non-Trajectory-Based Controller Protocol

The subject arrived and had blood pressure (BP) and heart rate (HR) measured by the PTs. The PTs then assisted the subject in overground gait for approximately 5 minutes to ensure the subject was warmed up. The subject then donned the inertial motion capture system (MVN Awinda inertial motion capture system, Xsens Technologies) consisting of a set of 17 motion trackers affixed to limb segments via elastic bands, with assistance from the PTs, and performed two timed 10MWTs while the subject's gait kinematics were recorded. The subject then doffed the motion capture system and donned the exoskeleton, both with PT assistance. With PTs providing balance assistance as needed the subject walked for 20 to 25 minutes in



approximately 5 minute increments. Figure 4.4 shows one of the subjects walking in the exoskeleton during a typical gait training session with the assistance of a PT. Subjects were allowed to rest as needed during the session. Following gait training, the subject doffed the exoskeleton with PT assistance and practiced walking without the exoskeleton for approximately 5 minutes to ensure a transition between the exoskeleton intervention and unassisted walking. The subject then donned the motion capture trackers with PT assistance and performed two additional 10MWTs, during which the subject's gait kinematics were recorded.



Figure 4.4. A subject walking in the Indego Exoskeleton. A PT is present to provide balance assistance if needed.

Because the NTB controller has numerous tunable parameters, it was necessary to adjust the controller settings to suit the assistive needs of each subject. This was performed during the therapy session and was considered to be part of the allocated 20 to 25 minutes of walking. Additional or incremental changes to assistive control components were made as requested by the PTs to achieve a desired level of exoskeleton assistance, as per the PTs' clinical judgment, during the session. The procedure for adjusting assistive control parameters during affected-leg swing was as follows: 1) the percentage of limb weight to be

compensated,  $r$ , was set to 0% initially and incremented until the subject achieved a desirable amount of hip flexion during swing; 2) the flexive feedforward torque pulses at the knee were set to 0 initially and gradually increased in extent until the subject achieved a desirable amount of knee flexion during swing; 3) the extensive feedforward torque pulses at the knee were set to 0 initially and gradually increased to achieve a desirable extent of knee extension at heel strike. The soft-stop boundaries in flexion and extension employed during affected-leg stance were initially set to 40 and 0 degrees respectively, which established a wide band of unimpeded motion around the knee. These boundaries were then adjusted as per the subject's and PT's discretion to create a higher degree of support around the specific subject's neutral joint angles if desired. Table III summarizes the tunable control parameters used for each subject, as recorded at the end of their second NTB therapy session (i.e. the final parameters they used with the NTB controller).

#### Trajectory-Based Controller Protocol

The protocol for the TB controller was nearly identical to that of the NTB controller. Subjects arrived, had BP and HR measurements taken, warmed up with PT assistance for 5 minutes, donned the motion capture trackers, performed two 10MWTs, doffed the motion capture trackers, donned the exoskeleton, walked for 20 to 25 minutes with rests as needed, doffed the exoskeleton, practiced walking without the exoskeleton (although with PT assistance) for 5 minutes, donned the motion capture trackers, performed two 10MWTs, and then doffed the motion capture trackers.

The TB controller has several tunable parameters, but subjects were typically able to walk in the system once the orientation threshold of the unaffected thigh was set to an appropriate level to permit easy step triggering by the subject. All subjects began training with a standardized set of parameters. Adjustments to joint excursion, step speed, or step length of the affected leg were made if desired by the PT to suit the needs of each subject. Table IV summarizes the final parameters used by each subject at the end of the second TB controller session.

## Control Protocol

The control sessions entailed a similar dosage of walking as the NTB and TB exoskeleton sessions, but without using the exoskeleton, henceforth referred to as the NE intervention. The protocol for the NE sessions differed significantly from the two exoskeleton protocols in that the subjects did not interact with an exoskeleton. As such the protocol was adjusted as follows: The subject arrived and had BP and HR measured by the PTs. The PTs then assisted the subject in overground gait for approximately 5 minutes to ensure the subject was warmed up. The subject then donned the motion capture trackers with assistance from the PTs and performed two timed 10MWTs while the subject's gait kinematics were recorded. The subject then doffed the motion capture trackers with PT assistance. The subject then walked for 20 to 25 minutes in approximately 5 minute increments. Subjects were allowed to rest as needed during the session. During this period, PTs coached the subject on improving their gait and manually assisted the subject as appropriate to improve the subject's gait kinematics. Examples of assistance include manually-assisted weight shifting, manually-assisted stance-limb support by bracing the subject's affected-side knee with the PTs hands, and balance assistance as needed. The subject then practiced overground gait for up to 5 minutes, after which the subject donned the motion capture trackers with PT assistance, and then performed two additional timed 10MWTs while the subject's gait kinematics were recorded.

TABLE 8  
Non-Trajectory Based Tunable Control Parameters  
for Each Subject

Subject	1	2	3
r (%)	55	50	65
P <sub>kf</sub> (Nm)	0	12	0
T <sub>kf</sub> (s)	0	0.3	0
P <sub>ke</sub> (Nm)	8	8	6
T <sub>ke</sub> (s)	0.5	0.5	.5
γ <sub>fss</sub> (deg)	18	13	25
γ <sub>ess</sub> (deg)	13	0	0

TABLE 9  
Trajectory Based Controller Tunable Control  
Parameters for Each Subject

Subject	1	2	3
Step time (s)	1.6	1.3	1.4
Early Stance Hip Angle (deg)	-2	5	3
Late Stance Hip Angle (deg)	-12	-5	-10
Peak Swing Hip Angle	45	45	45
Stance Knee Angle (deg)	10	5	2
Peak Knee Swing Angle (deg)	50	60	55
Step Trigger Threshold (deg)	-12	-12	-12

### Results

As with the authors' previous preliminary study, this study assessed single-session gains resulting from the intervention, rather than cumulative gains resulting from consistent dosing. Single-session effects are defined as differences in gait characteristics measured immediately after a single intervention session, relative to those measured immediately before. Such differences are attributable with a high degree of confidence to the intervention. Assessing single-session gains enables collection of multiple data points without undue burden on each subject, and with a reasonable expenditure of experimental resources. Further, the existence of single-session gains are a necessary condition for cumulative gains, and thus, demonstration of successful single-session gains is a prerequisite for demonstration of long-term gains. Finally, single-session gains are presumably not confounded by issues of spontaneous recovery. Despite the rationale for assessing single-session gains, demonstration of such gains are clearly not sufficient to demonstrate long-term recovery, and thus any promising single-session outcomes must eventually be substantiated with longitudinal studies that validate cumulative gains and persistence of effect associated with the intervention.

The single-session effects of each controller were assessed by comparing the motion capture data recorded during the pre-session and post-session 10MWTs. Fast gait speed (FGS) was selected as the primary outcome measure, with secondary outcome measures of stride length (SL), affected-side knee

excursion (ASKE), and affected-side hip excursion (ASHE). FGS was measured by timing the 10MWT. SL data was extracted via motion capture post-processing of the 10MWT data, and is defined as the distance travelled during two consecutive steps. ASKE and ASHE data were extracted via motion capture data analysis and were defined as the peak flexion angle achieved by the joint during a gait cycle minus the maximum extension angle achieved by the joint during the same cycle, averaged across all strides of the 10MWT.

Figs. 4.5 and 4.6 display average improvement for each of the measured gait parameters, averaged across all subjects and all sessions, separated by type of intervention (i.e., exoskeleton with NTB control, exoskeleton with TB control, and walking without the exoskeleton). As is evident in the figure, all interventions resulted in improvements in the measured gait metrics, with the exceptions of the NE condition slightly decreasing SL on average, and the TB controller having essentially no impact on ASHE. As is also evident, the NTB controller produced the largest average single-session gains in FGS, SL, and ASKE, and produced results similar to those of the NE condition in ASHE. Change values for each subject and each session are tabulated in Table 5 along with the calculated average values.

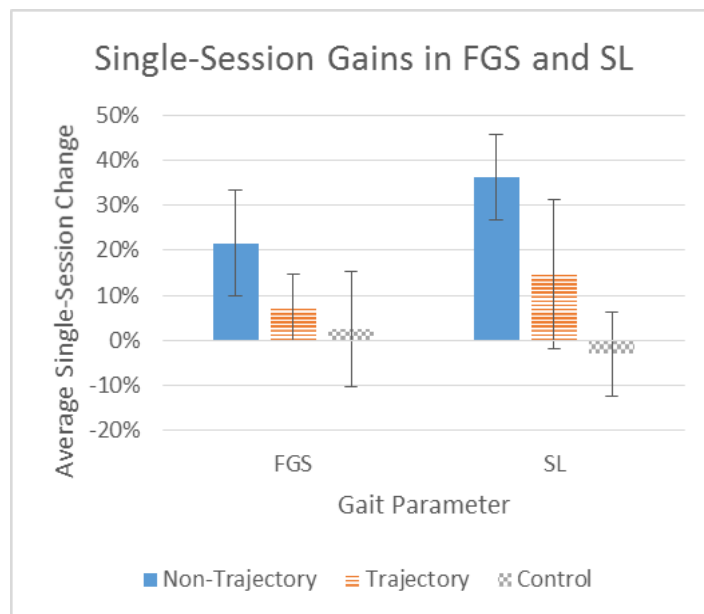

Figure 4.5. Single-session changes in FGS and SL for each controller, averaged across all subjects and all sessions. Error bars indicate the Standard Error of the Mean (SEM).

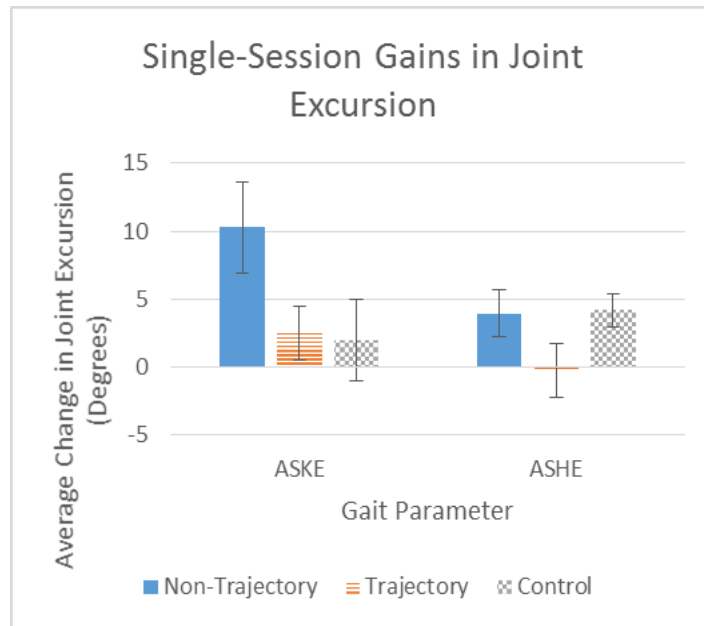

Figure 4.6. Single-session changes in ASKE and ASHE for each controller, averaged across all subjects and all sessions. Error bars indicate the Standard Error of the mean (SEM).

### Discussion

The goal of these experiments was to assess the relative value of two robotically-assisted control paradigms in facilitating gait recovery in subjects with lower limb hemiparesis from CVA. Specifically, the study compared the relative efficacy of a NTB control approach and a TB control approach, both relative to overground gait training with an exoskeleton. Because all subjects participated in therapy with each therapy condition, intra-subject comparisons of the efficacy of each therapy condition can be made.

After training in the exoskeleton with the NTB controller, Subject 1 experienced increased FGS and SL, suggesting that the subject had an overall improved gait pattern. When training in the TB controller, Subject 1 demonstrated greatly increased SL, but did not have a corresponding increase in FGS, suggesting that the increase in SL may not have been productive (i.e., the increase may have been so large as to reduce stability, resulting in a reduction in gait efficacy). Conversely, when training with PT assistance in the NE condition, Subject 1 improved FGS despite a seemingly contradictory decrease in SL. In this case, the reduction in SL likely stabilized the subject, permitting an overall increase to FGS. Subject 1's ASKE and

ASHE both increased when training in the NTB controller, and demonstrated mixed results (increased ASKE and decreased ASHE) when training in the TB controller or in the NE condition (increased ASHE and decreased ASKE). All increases and decreases in joint excursion exhibited by Subject 1 were small in magnitude, and were unlikely to have had large impacts on the subject’s overall gait.

TABLE 10  
Change in Gait Variables For each Session

		FGS Change (%)		SL Change (%)		ASKE Change (degrees)		ASHE Change (degrees)	
	Therapy Condition	Session 1	Session 2	Session 1	Session 2	Session 1	Session 2	Session 1	Session 2
Subject 1	Non-Trajectory Based	21.0	13.1	24.2	46.5	8.9	-3.1	3.7	6.3
	Trajectory Based	17.7	-17.2	103.2	-18.3	5.5	-1.3	-2.2	-3.2
	Control	9.2	0.5	-30.4	-21.1	-11.7	8.5	-1.0	8.1
Subject 2	Non-Trajectory Based	Session 1 -11.41	Session 2 -*	Session 1 -8.4	Session 2 -*	Session 1 13.0	Session 2 -*	Session 1 -2.4	Session 2 -*
	Trajectory Based	-2.0	-5.3	-2.6	-9.7	1.1	2.8	-0.2	-0.1
	Control	-61.2	41.8	-6.7	19.6	4.2	-3.3	4.7	6.0
Subject 3	Non-Trajectory Based	Session 1 29.9	Session 2 55.6	Session 1 50.0	Session 2 69.3	Session 1 18.9	Session 2 13.72	Session 1 3.1	Session 2 9.1
	Trajectory Based	12.0	38.8	14.4	1.0	1.2	6.0	0.2	3.6
	Control	17.4	6.7	35.0	-14.4	7.6	6.8	5.3	1.8
Average	Non-Trajectory Based	21.6		36.3		10.3		4.0	
	Trajectory Based	7.3		14.7		2.5		-0.3	
	Control	2.4		-3.0		2.0		4.2	

\*During subject 2’s second session with the non-trajectory based controller, knee joint stability reinforcement during stance was unintentionally active at the subject’s unaffected-side knee. This caused substantial issues with the subject’s balance during the session, and single-session gains for this session were not included in the analysis.

Subject 2 did not respond positively to any of the therapy conditions. The subject experienced decreases in FGS after training with all three of the conditions, and had similar decreases in SL when training with either the trajectory-based controller or the NTB controller. Only training with the NE condition acted to slightly increase SL, but with reduced FGS, suggesting the gain was not indicative of significantly improved gait. Subject 2 did, however, demonstrate a large increase in ASKE after training in the NTB controller, but with a corresponding small decrease in ASHE. The TB controller had little to no impact on the subject's joint excursion, and the control condition had no impact on ASKE, but resulted in a small improvement in ASHE. The cause of Subject 2's negative responses to all therapy conditions is unclear, especially in consideration of the large gains made by subjects with both longer and shorter time since injury, and faster and slower initial gait speeds. These results make a comparison of controller efficacy ill-posed for this subject (none appear to have improved the subject's gait), and additionally suggest that overground gait training may not be effective for this subject.

Improvements exhibited by Subject 3 showed agreement with Subject 1 in that both FGS and SL experienced the largest gains with the NTB controller, reduced gains with the TB controller, and the smallest gains in the NE condition. The largest gains in ASHE and ASKE were made with the NTB controller as well, while the NE condition produced reduced gains, and the TB controller produced the smallest gains. Overall, Subject 3 made the largest gains in all outcome measures when training with the NTB controller.

In spite of the equivocal results from Subject 2, when averaged across all subjects, the NTB controller provided statistically significant improvements in ASKE and ASHE relative to the TB controller (based on paired t-tests with 90% confidence). The NTB controller also provided improvements in mean values relative to the TB controller in FGS and SL, although perhaps due to the limited number of subjects and trials, the differences were not statistically significant. Relative to the NE condition, the NTB controller provided statistically significant improvements in SL and ASKE (based on paired t-tests with 90% confidence). The NTB controller also provided improvements in the mean value of FGS, although the



differences were not statistically significant. Relative to the NE condition, the TB controller provided a statistically significant decrease in ASHE (i.e., was less effective than the NE condition), while providing no statistically significant differences in the other gait metrics.

Based on these outcomes, it appears that an exoskeleton intervention using a non-trajectory-based control approach may offer greater recovery benefit than walking without an exoskeleton (specifically with respect to promoting greater joint excursions), while walking in an exoskeleton employing a trajectory-based control approach may not offer benefit relative to overground training without an exoskeleton. Given the statistical limitations of this study, however, in combination with the high-degree of heterogeneity in the study population, the confidence with which one can draw strong conclusions is limited. Further studies consisting of randomized controlled trials with larger number of patients with substantially greater dosing and measuring cumulative effects will be required in order to assess the validity of these observations. Regardless, the single-session study results do indicate, as hypothesized, that a controller that permits the patient to dictate the spatiotemporal nature of gait may better facilitate recovery of gait, at least in the short term. Among other observations, the results indicate that the manner with which an exoskeleton physically interacts with a patient may have a significant effect on recovery outcomes (i.e., the control approach matters).

### Conclusion

This paper presents a small study comparing the extent to which two exoskeleton control paradigms might affect walking recovery. Specifically, the study measured single-session outcomes of gait therapy, where the gait therapy consisted of overground walking within an exoskeleton with two different control paradigms. One control paradigm dictated the spatiotemporal nature of joint movement (i.e., dictated joint movement completely) in the paretic limb, while the other control paradigm provided assistive torques, but did so without dictating joint motion. Outcomes from both cases were also compared to overground gait training without an exoskeleton. Results of the study indicate that overground gait training with an

exoskeleton is most effective when the exoskeleton controller does not dictate joint motion (i.e., employs a non-trajectory-based controller), in which case the exoskeleton provides significantly better results than overground training without an exoskeleton. Further, use of an exoskeleton with a trajectory-based controller appears to provide no better outcomes than walking without an exoskeleton. As such, although preliminary, the results of this study indicate that the manner in which an exoskeleton is controlled may have a significant effect on the efficacy of the device in providing gait recovery in individuals with lower-limb hemiparesis.

#### ADDENDUM

The crossover nature of the study reported in Manuscript IV is of particular importance in that it permitted a precise analysis of the differences between control methods without the potentially confounding effects of different hardware. By implementing both control methods on the Indego exoskeleton, device weight, device sensor considerations, device number of actuated joints/degrees of freedom, device conformance to the user's body, etc. are all kept constant such that any differences in outcome can be attributed with a high degree of certainty to NTB vs. TB control. Had the TB controller been implemented on the HAL exoskeleton or Lokomat, for instance, any observed differences might have been clouded by these considerations. Furthermore, the use of the XSENS motion capture system permitted a deeper analysis of user gait than was possible in the study presented as Manuscript III. For example, while a subject's gait in the exoskeleton could be captured during the Manuscript III experiment, comparison to the same subject's gait outside the exoskeleton was impossible. With the XSENS system we were able to capture a full profile of a subject's gait for comparison. Although not included with the submitted Manuscript IV, the figure below is of interest in that it demonstrates the ability of both exoskeleton controllers to increase joint excursion *while wearing* the exoskeleton. The ultimate goal in gait training is to produce alterations in gait which remain after removing the RAGT system, but this figure clearly indicates increased joint excursion (and prevention of hyper extension in the stance knee), suggesting that the device is largely assistive, rather than resistive.

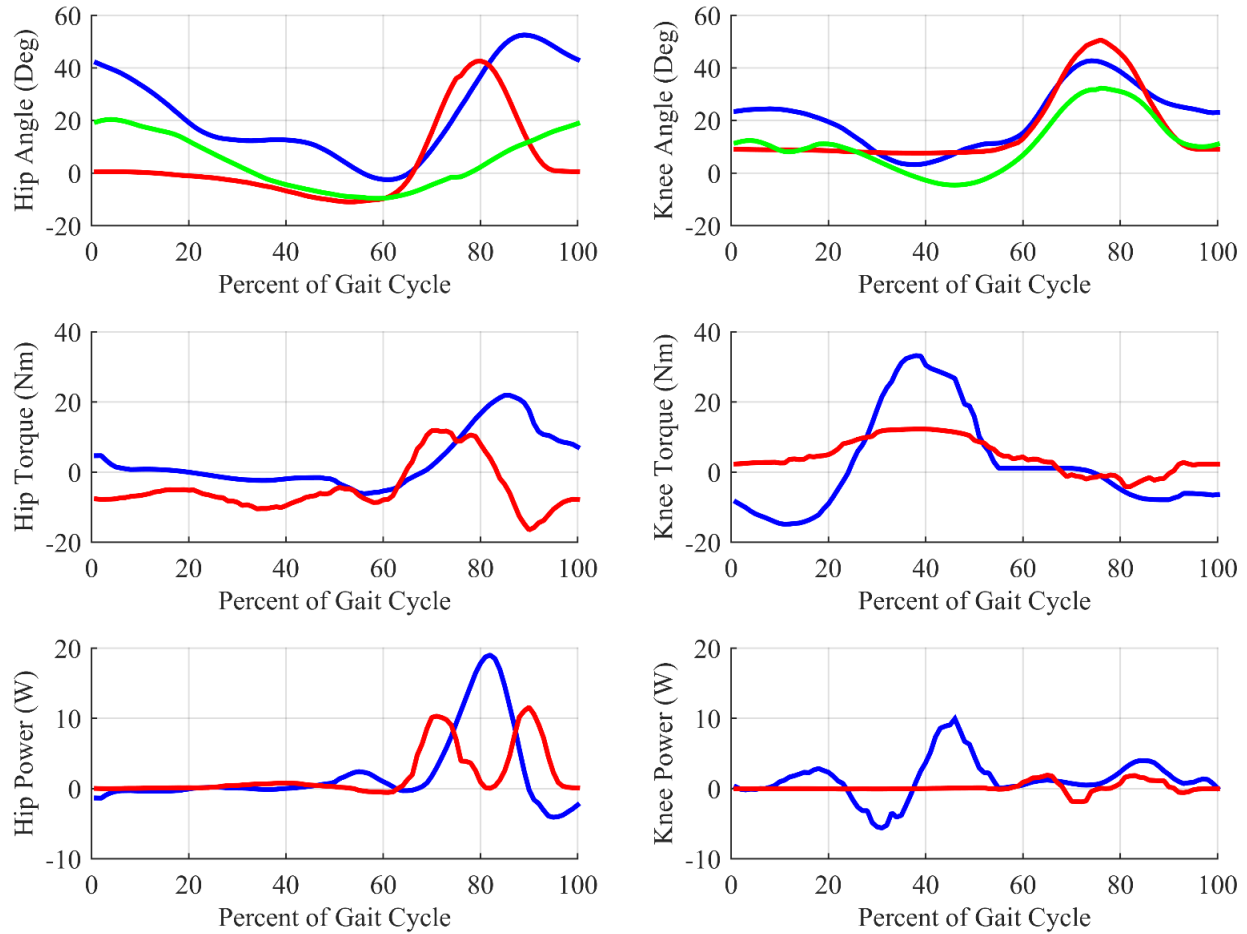

Figure 4.7. Graphs depict subject 1's affected-side hip (a.) and knee (b.) angles when walking without use of the exoskeleton (green), when walking with the trajectory based controller (red), and when walking with the non-trajectory based controller (blue), each averaged over 10 consecutive strides. The next row of graphs compares the hip torque (c.) and knee torque (d.) produced by the exoskeleton throughout the gait cycle. The final row compares hip (e.) and knee (f.) power. Note that while both controllers achieve the goals of increasing hip and knee excursion and preventing knee hyperextension during stance, the torque and power profiles for the trajectory based and non-trajectory based controller differ significantly. In particular, the non-trajectory based controller provides positive power in most instances, but negative power at the hip during late swing and at the knee during mid stance, while the trajectory based controller provides almost exclusively positive power.

It is also worth mentioning that all subjects who participated in this test were considered to be in the “chronic” phase of recovery from CVA (i.e. more than 6 months post incident). This is important as it indicates that these subjects were not expected to undergo any spontaneous recovery over the six-week course of the experiment. Indeed, although the study was too small in scope to make claims about retention of improvements, the two subjects who did respond positively to training in any of the conditions made substantial gains in their gait speed by week six. Subject 1 had an average 10 meter walk test (10MWT) time of 18.5 seconds prior to training in week 1 and improved to 10.9 seconds prior to training in week 6. Subject 3 had a similar improvement, reducing 10MWT time from 37.1 prior to training in week 1 to 21.3. This indicates that over the course of the training, persistence of effect was observed. Whether these gains would be maintained six months post-training is unclear.

## CHAPTER VI

### CONCLUSION AND FUTURE WORK

This dissertation presents the development of an exoskeleton controller which does not operate on a trajectory basis. The controller has been tested for efficacy in restoring gait functionality in patients recovering from CVA. The document begins by walking through the initial work performed to demonstrate that the passive dynamics of the exoskeleton could be minimized with active compensation. A second manuscript was then presented which detailed work in developing a new method of measuring task engagement in a multi-limb-coordinated motor-learning paradigm. The results revealed a statistically significant correlation between a set of physiological signals and the difficulty level of the task. Control data supported the hypothesis that these increases were related to mental engagement and not physical exertion. Following this, a manuscript was presented which detailed the full development of the non-trajectory-based (NTB) controller, which included some exoskeleton gravity compensation, user limb-weight compensation, joint stability reinforcement, and feedforward assistive torque components, none of which rely on a dictated trajectory to function. Data collected from a preliminary study of the controller's effects on patients recovering from CVA supported the hypothesis that a NTB controller was capable of facilitating gait recovery when implemented in an overground exoskeleton. Finally, in order to offer context for the single-session improvements measured in these experiments, a second preliminary study was performed in order to compare the effects of a trajectory based (TB) controller, conventional overground therapy (CT) with physical therapist assistance, and the novel NTB controller. The collected data support the hypothesis that a NTB controller better facilitates the recovery of gait functionality in subjects recovering from CVA. At this point, data have been collected from six subjects with a range of impairment levels from hemiparesis. The NTB controller has demonstrated the ability to produce single-session gains which appear to be greater in magnitude than gains made when training with a TB controller or when participating in CT with a skilled physical therapist.

The ultimate goals in gait rehabilitation are twofold. First, it is necessary to improve the gait of the recovering patient in a meaningful way, and second, it is necessary to ensure that those gains are maintained in the long term. This dissertation has accomplished the first goal, demonstrating the NTB controller's ability to produce gains in the gait parameters of subjects recovering from CVA. The long term persistence of these gains remains to be demonstrated, and is perhaps the most important goal of future studies of the controller. As noted by post-doctoral researcher Brian E. Lawson, Ph.D, in his doctoral thesis, validation of research on the scale of large randomized controlled trials is typically outside the scope of our lab, the Vanderbilt Center for Intelligent Mechatronics [100]. However, the next steps in evaluating the efficacy of this controller require such testing. The first experiment which should be performed is a study of cumulative effects when a small number of subjects participate in exoskeleton therapy multiple times per week for multiple weeks. This will determine whether the single-session gains quickly plateau, or whether they continue to improve gait functionality. This test should be performed with a small number of selected candidates, rather than a large pool of subjects.

Following the study of cumulative effects, it will be necessary to perform an RCT study. The exoskeleton project has benefitted greatly from the commercialization of the Indego exoskeleton. The NTB controller has been licensed by Parker Hannifin and is currently being considered for commercial hardening as a potential control method for the Indego exoskeleton. This will require a clinical trial which will permit analysis of the effects of long-term dosing with the controller (i.e. multiple sessions per week for several weeks) as well as improvement retention after the conclusion of training (via follow-up sessions). This work will definitively establish whether the NTB controller is capable of producing improved functional outcomes in patients recovering from CVA. If the results of such a trial are positive, the controller may have a significant impact on patients undergoing gait rehabilitation.

The results of a large-scale clinical trial await, but the results of the preliminary studies of the NTB controller are in and of themselves an accomplishment. Prior to this work, no controller for overground exoskeletons had been developed which did not operate on a trajectory basis. The goal of much of the research found in the literature is not to move away from a trajectory basis of control, but rather to alter the

method of trajectory enforcement or trajectory generation. The non-trajectory-based controller presented in this dissertation has presented an entirely novel philosophy for exoskeleton control. Whether this philosophy proves to greatly change the prognosis for the thousands of people recovering from CVA remains to be seen.

## REFERENCES

- [1] R. J. Farris, H. A. Quintero, and M. Goldfarb, "Preliminary Evaluation of a Powered Lower Limb Orthosis to Aid Walking in Paraplegic Individuals," *Neural Systems and Rehabilitation Engineering, IEEE Transactions on*, vol. 19, pp. 652-659, 2011.
- [2] R. J. Farris, H. A. Quintero, and M. Goldfarb, "Performance evaluation of a lower limb exoskeleton for stair ascent and descent with Paraplegia," in *Engineering in Medicine and Biology Society (EMBC), 2012 Annual International Conference of the IEEE*, 2012, pp. 1908-1911.
- [3] R. J. Farris, H. A. Quintero, S. A. Murray, K. H. Ha, C. Hartigan, and M. Goldfarb, "A Preliminary Assessment of Legged Mobility Provided by a Lower Limb Exoskeleton for Persons With Paraplegia," *IEEE Transactions on Neural Systems and Rehabilitation Engineering*, vol. 22, pp. 482-490, 2014.
- [4] K. H. Ha, H. A. Quintero, R. J. Farris, and M. Goldfarb, "Enhancing stance phase propulsion during level walking by combining fes with a powered exoskeleton for persons with paraplegia," in *Engineering in Medicine and Biology Society (EMBC), 2012 Annual International Conference of the IEEE*, 2012, pp. 344-347.
- [5] C. Hartigan, M. Goldfarb, R. Farris, K. Ha, and S. Murray, "Poster 19 Newly Developed Robotic Exoskeleton That Provides Mobility and Option for Functional Electrical Stimulation," *Archives of Physical Medicine and Rehabilitation*, vol. 94, pp. e18-e19.
- [6] C. Hartigan, C. Kandilakis, S. Dalley, M. Clausen, E. Wilson, S. Morrison, S. Etheridge, and R. Farris, "Mobility outcomes following five training sessions with a powered exoskeleton," *Topics in spinal cord injury rehabilitation*, vol. 21, pp. 93-99, 2015.
- [7] H. A. Quintero, R. J. Farris, and M. Goldfarb, "A Method for the Autonomous Control of Lower Limb Exoskeletons for Persons With Paraplegia," *Journal of Medical Devices*, vol. 6, pp. 041003-041003, 2012.
- [8] H. A. Quintero, R. J. Farris, and M. Goldfarb, "Control and implementation of a powered lower limb orthosis to aid walking in paraplegic individuals," in *Rehabilitation Robotics (ICORR), 2011 IEEE International Conference on*, 2011, pp. 1-6.
- [9] H. A. Quintero, R. J. Farris, K. Ha, and M. Goldfarb, "Preliminary assessment of the efficacy of supplementing knee extension capability in a lower limb exoskeleton with FES," in *Engineering in Medicine and Biology Society (EMBC), 2012 Annual International Conference of the IEEE*, 2012, pp. 3360-3363.
- [10] H. A. Quintero, R. J. Farris, C. Hartigan, I. Clesson, and M. Goldfarb, "A Powered Lower Limb Orthosis for Providing Legged Mobility in Paraplegic Individuals," *Topics in Spinal Cord Injury Rehabilitation*, vol. 17, pp. 25-33, 2011.
- [11] A. S. Go, D. Mozaffarian, V. L. Roger, E. J. Benjamin, J. D. Berry, M. J. Blaha, S. Dai, E. S. Ford, C. S. Fox, and S. Franco, "Heart disease and stroke statistics--2014 update: a report from the American Heart Association," *Circulation*, vol. 129, p. e28, 2014.
- [12] M. G. Bowden, C. K. Balasubramanian, A. L. Behrman, and S. A. Kautz, "Validation of a speed-based classification system using quantitative measures of walking performance poststroke," *Neurorehabilitation and neural repair*, vol. 22, pp. 672-675, 2008.
- [13] G. Andersen, K. Vestergaard, M. Ingemann-Nielsen, and L. Lauritzen, "Risk factors for post-stroke depression," *Acta Psychiatrica Scandinavica*, vol. 92, pp. 193-198, 1995.
- [14] J. Perry, M. Garrett, J. K. Gronley, and S. J. Mulroy, "Classification of walking handicap in the stroke population," *Stroke*, vol. 26, pp. 982-989, 1995.
- [15] R. W. Bohannon, A. W. Andrews, and M. B. Smith, "Rehabilitation goals of patients with hemiplegia," *International Journal of Rehabilitation Research*, vol. 11, pp. 181-184, 1988.
- [16] R. P. Stroemer, T. A. Kent, and C. E. Hulsebosch, "Neocortical neural sprouting, synaptogenesis, and behavioral recovery after neocortical infarction in rats," *Stroke*, vol. 26, pp. 2135-2144, 1995.



- [17] W. T. Greenough, J. R. Larson, and G. S. Withers, "Effects of unilateral and bilateral training in a reaching task on dendritic branching of neurons in the rat motor-sensory forelimb cortex," *Behavioral and neural biology*, vol. 44, pp. 301-314, 1985.
- [18] N. S. Ward and R. S. Frackowiak, "The functional anatomy of cerebral reorganisation after focal brain injury," *Journal of Physiology-Paris*, vol. 99, pp. 425-436, 2006.
- [19] H. Schmidt, C. Werner, R. Bernhardt, S. Hesse, and J. Krüger, "Gait rehabilitation machines based on programmable footplates," *Journal of neuroengineering and rehabilitation*, vol. 4, p. 2, 2007.
- [20] S. L. Morris, K. J. Dodd, and M. E. Morris, "Outcomes of progressive resistance strength training following stroke: a systematic review," *Clinical Rehabilitation*, vol. 18, pp. 27-39, 2004.
- [21] M. M. Ouellette, N. K. LeBrasseur, J. F. Bean, E. Phillips, J. Stein, W. R. Frontera, and R. A. Fielding, "High-intensity resistance training improves muscle strength, self-reported function, and disability in long-term stroke survivors," *Stroke*, vol. 35, pp. 1404-1409, 2004.
- [22] U.-B. Flansbjerg, M. Miller, D. Downham, and J. Lexell, "Progressive resistance training after stroke: effects on muscle strength, muscle tone, gait performance and perceived participation," *Journal of Rehabilitation Medicine*, vol. 40, pp. 42-48, 2008.
- [23] P. W. Duncan, K. J. Sullivan, A. L. Behrman, S. P. Azen, S. S. Wu, S. E. Nadeau, B. H. Dobkin, D. K. Rose, J. K. Tilson, and S. Cen, "Body-weight-supported treadmill rehabilitation after stroke," *New England Journal of Medicine*, vol. 364, pp. 2026-2036, 2011.
- [24] S. Hesse, C. Bertelt, A. Schaffrin, M. Malezic, and K.-H. Mauritz, "Restoration of gait in nonambulatory hemiparetic patients by treadmill training with partial body-weight support," *Archives of physical medicine and rehabilitation*, vol. 75, pp. 1087-1093, 1994.
- [25] S. Hesse, C. Bertelt, M. Jahnke, A. Schaffrin, P. Baake, M. Malezic, and K. Mauritz, "Treadmill training with partial body weight support compared with physiotherapy in nonambulatory hemiparetic patients," *Stroke*, vol. 26, pp. 976-981, 1995.
- [26] H. Barbeau and M. Visintin, "Optimal outcomes obtained with body-weight support combined with treadmill training in stroke subjects," *Archives of physical medicine and rehabilitation*, vol. 84, pp. 1458-1465, 2003.
- [27] K. J. Sullivan, D. A. Brown, T. Klassen, S. Mulroy, T. Ge, S. P. Azen, and C. J. Winstein, "Effects of task-specific locomotor and strength training in adults who were ambulatory after stroke: results of the STEPS randomized clinical trial," *Physical therapy*, vol. 87, pp. 1580-1602, 2007.
- [28] J. H. Kahn and T. G. Hornby, "Rapid and long-term adaptations in gait symmetry following unilateral step training in people with hemiparesis," *Physical therapy*, vol. 89, pp. 474-483, 2009.
- [29] D. S. Reisman, R. Wityk, K. Silver, and A. J. Bastian, "Locomotor adaptation on a split-belt treadmill can improve walking symmetry post-stroke," *Brain*, vol. 130, pp. 1861-1872, 2007.
- [30] D. S. Reisman, R. Wityk, K. Silver, and A. J. Bastian, "Split-belt treadmill adaptation transfers to overground walking in persons poststroke," *Neurorehabilitation and neural repair*, vol. 23, pp. 735-744, 2009.
- [31] B. H. Dobkin and P. W. Duncan, "Should Body Weight-Supported Treadmill Training and Robotic-Assistive Steppers for Locomotor Training Trot Back to the Starting Gate?," *Neurorehabilitation and neural repair*, vol. 26, pp. 308-317, 2012.
- [32] C. Sherrington, J. C. Whitney, S. R. Lord, R. D. Herbert, R. G. Cumming, and J. C. Close, "Effective exercise for the prevention of falls: a systematic review and meta-analysis," *Journal of the American Geriatrics Society*, vol. 56, pp. 2234-2243, 2008.
- [33] Hocoma. (March 20th, 2016). *LokomatPro Brochure* [pdf]. Available: [https://www.hocoma.com/fileadmin/user/Dokumente/Lokomat/bro\\_LokomatPro\\_141008\\_en.pdf](https://www.hocoma.com/fileadmin/user/Dokumente/Lokomat/bro_LokomatPro_141008_en.pdf)
- [34] G. Colombo, M. Joerg, R. Schreier, and V. Dietz, "Treadmill training of paraplegic patients using a robotic orthosis," *Journal of rehabilitation research and development*, vol. 37, pp. 693-700, 2000.
- [35] G. Colombo, M. Wirz, and V. Dietz, "Driven gait orthosis for improvement of locomotor training in paraplegic patients," *Spinal Cord*, vol. 39, pp. 252-255, 2001.

- [36] R. K. Tong, M. F. Ng, and L. S. Li, "Effectiveness of gait training using an electromechanical gait trainer, with and without functional electric stimulation, in subacute stroke: a randomized controlled trial," *Archives of physical medicine and rehabilitation*, vol. 87, pp. 1298-1304, 2006.
- [37] J. L. Emken, S. J. Harkema, J. A. Beres-Jones, C. K. Ferreira, and D. J. Reinkensmeyer, "Feasibility of Manual Teach-and-Replay and Continuous Impedance Shaping for Robotic Locomotor Training Following Spinal Cord Injury," *Biomedical Engineering, IEEE Transactions on*, vol. 55, pp. 322-334, 2008.
- [38] R. Ekkelenkamp, J. Veneman, and H. van der Kooij, "LOPES: selective control of gait functions during the gait rehabilitation of CVA patients," in *Rehabilitation Robotics, 2005. ICORR 2005. 9th International Conference on*, 2005, pp. 361-364.
- [39] J. F. Veneman, R. Kruidhof, E. E. G. Hekman, R. Ekkelenkamp, E. H. F. Van Asseldonk, and H. van der Kooij, "Design and Evaluation of the LOPES Exoskeleton Robot for Interactive Gait Rehabilitation," *Neural Systems and Rehabilitation Engineering, IEEE Transactions on*, vol. 15, pp. 379-386, 2007.
- [40] S. K. Banala, K. Seok Hun, S. K. Agrawal, and J. P. Scholz, "Robot Assisted Gait Training With Active Leg Exoskeleton (ALEX)," *Neural Systems and Rehabilitation Engineering, IEEE Transactions on*, vol. 17, pp. 2-8, 2009.
- [41] H. Vallery, A. Duschau-Wicke, and R. Riener, "Generalized elasticities improve patient-cooperative control of rehabilitation robots," in *Rehabilitation Robotics, 2009. ICORR 2009. IEEE International Conference on*, 2009, pp. 535-541.
- [42] T. Lenzi, D. Zanotto, P. Stegall, M. Carrozza, and S. K. Agrawal, "Reducing muscle effort in walking through powered exoskeletons," in *Engineering in Medicine and Biology Society (EMBC), 2012 Annual International Conference of the IEEE*, 2012, pp. 3926-3929.
- [43] A. Esquenazi, M. Talaty, A. Packel, and M. Saulino, "The ReWalk powered exoskeleton to restore ambulatory function to individuals with thoracic-level motor-complete spinal cord injury," *American Journal of Physical Medicine & Rehabilitation*, vol. 91, pp. 911-921, 2012.
- [44] S. Maeshima, A. Osawa, D. Nishio, Y. Hirano, K. Takeda, H. Kigawa, and Y. Sankai, "Efficacy of a hybrid assistive limb in post-stroke hemiplegic patients: a preliminary report," *BMC neurology*, vol. 11, p. 116, 2011.
- [45] H. Watanabe, N. Tanaka, T. Inuta, H. Saitou, and H. Yanagi, "Locomotion Improvement Using a Hybrid Assistive Limb in Recovery Phase Stroke Patients: A Randomized Controlled Pilot Study," *Archives of physical medicine and rehabilitation*, vol. 95, pp. 2006-2012, 2014.
- [46] A. Nilsson, K. S. Vreede, V. Häglund, H. Kawamoto, Y. Sankai, and J. Borg, "Gait training early after stroke with a new exoskeleton—the hybrid assistive limb: a study of safety and feasibility," *Journal of neuroengineering and rehabilitation*, vol. 11, p. 92, 2014.
- [47] M. Bortole, A. Venkatakrishnan, F. Zhu, J. C. Moreno, G. E. Francisco, J. L. Pons, and J. L. Contreras-Vidal, "The H2 robotic exoskeleton for gait rehabilitation after stroke: early findings from a clinical study," *Journal of neuroengineering and rehabilitation*, vol. 12, p. 1, 2015.
- [48] T. G. Hornby, D. D. Campbell, J. H. Kahn, T. Demott, J. L. Moore, and H. R. Roth, "Enhanced gait-related improvements after therapist-versus robotic-assisted locomotor training in subjects with chronic stroke a randomized controlled study," *Stroke*, vol. 39, pp. 1786-1792, 2008.
- [49] J. Hidler, D. Nichols, M. Pelliccio, K. Brady, D. D. Campbell, J. H. Kahn, and T. G. Hornby, "Multicenter randomized clinical trial evaluating the effectiveness of the Lokomat in subacute stroke," *Neurorehabilitation and neural repair*, vol. 23, pp. 5-13, 2009.
- [50] M. Pohl, C. Werner, M. Holzgraefe, G. Kroczeck, I. Wingendorf, G. Hoölig, R. Koch, and S. Hesse, "Repetitive locomotor training and physiotherapy improve walking and basic activities of daily living after stroke: a single-blind, randomized multicentre trial (DEutsche GANgtrainerStudie, DEGAS)," *Clinical rehabilitation*, vol. 21, pp. 17-27, 2007.
- [51] I. Schwartz, A. Sajin, I. Fisher, M. Neeb, M. Shochina, M. Katz-Leurer, and Z. Meiner, "The effectiveness of locomotor therapy using robotic-assisted gait training in subacute stroke patients: a randomized controlled trial," *PM&R*, vol. 1, pp. 516-523, 2009.

- [52] J. Mehrholz, B. Elsner, C. Werner, J. Kugler, and M. Pohl, "Electromechanical-assisted training for walking after stroke," *The Cochrane Library*, 2013.
- [53] R. P. Van Peppen, G. Kwakkel, S. Wood-Dauphinee, H. J. Hendriks, P. J. Van der Wees, and J. Dekker, "The impact of physical therapy on functional outcomes after stroke: what's the evidence?," *Clinical rehabilitation*, vol. 18, pp. 833-862, 2004.
- [54] M. Rensink, M. Schuurmans, E. Lindeman, and T. Hafsteinsdottir, "Task-oriented training in rehabilitation after stroke: systematic review," *Journal of advanced nursing*, vol. 65, pp. 737-754, 2009.
- [55] A. Kaelin-Lang, L. Sawaki, and L. G. Cohen, "Role of voluntary drive in encoding an elementary motor memory," *Journal of neurophysiology*, vol. 93, pp. 1099-1103, 2005.
- [56] H. Barbeau and S. Rossignol, "Recovery of locomotion after chronic spinalization in the adult cat," *Brain research*, vol. 412, pp. 84-95, 1987.
- [57] R. Lovely, R. Gregor, R. Roy, and V. Edgerton, "Weight-bearing hindlimb stepping in treadmill-exercised adult spinal cats," *Brain research*, vol. 514, pp. 206-218, 1990.
- [58] S. J. Harkema, "Plasticity of interneuronal networks of the functionally isolated human spinal cord," *Brain research reviews*, vol. 57, pp. 255-264, 2008.
- [59] V. L. Roger, A. S. Go, D. M. Lloyd-Jones, R. J. Adams, J. D. Berry, T. M. Brown, M. R. Carnethon, S. Dai, G. de Simone, E. S. Ford, C. S. Fox, H. J. Fullerton, C. Gillespie, K. J. Greenlund, S. M. Hailpern, J. A. Heit, P. M. Ho, V. J. Howard, B. M. Kissela, S. J. Kittner, D. T. Lackland, J. H. Lichtman, L. D. Lisabeth, D. M. Makuc, G. M. Marcus, A. Marelli, D. B. Matchar, M. M. McDermott, J. B. Meigs, C. S. Moy, D. Mozaffarian, M. E. Mussolino, G. Nichol, N. P. Paynter, W. D. Rosamond, P. D. Sorlie, R. S. Stafford, T. N. Turan, M. B. Turner, N. D. Wong, and J. Wylie-Rosett, "Heart disease and stroke statistics--2011 update: a report from the American Heart Association," *Circulation*, vol. 123, pp. e18-e209, 2011.
- [60] K. W. Krigger, "Cerebral palsy: an overview," *Am Fam Physician*, vol. 73, pp. 91-100, 2006.
- [61] D. W. Anderson, J. H. Ellenberg, C. M. Leventhal, S. C. Reingold, M. Rodriguez, and D. H. Silberberg, "Revised estimate of the prevalence of multiple sclerosis in the united states," *Annals of Neurology*, vol. 31, pp. 333-336, 1992.
- [62] D. A. Winter, *The biomechanics and motor control of human gait: normal, elderly and pathological*, 2nd ed.: University of Waterloo Press, 1991.
- [63] R. J. Sanchez, J. Liu, S. Rao, P. Shah, R. Smith, T. Rahman, S. C. Cramer, J. E. Bobrow, and D. J. Reinkensmeyer, "Automating arm movement training following severe stroke: functional exercises with quantitative feedback in a gravity-reduced environment," *IEEE Trans Neural Syst Rehabil Eng*, vol. 14, pp. 378-89, 2006.
- [64] H. I. Krebs, J. J. Palazzolo, L. Dipietro, M. Ferraro, J. Krol, K. Ranekleiv, B. T. Volpe, and N. Hogan, "Rehabilitation robotics: Performance-based progressive robot-assisted therapy," *Autonomous Robots*, vol. 15, pp. 7-20, 2003.
- [65] E. T. Wolbrecht, V. Chan, V. Le, S. C. Cramer, D. J. Reinkensmeyer, and J. E. Bobrow, "Real-time computer modeling of weakness following stroke optimizes robotic assistance for movement therapy," in *Neural Engineering, 2007. CNE'07. 3rd International IEEE/EMBS Conference on*, 2007, pp. 152-158.
- [66] J. Mehrholz and M. Pohl, "Electromechanical-assisted gait training after stroke: a systematic review comparing end-effector and exoskeleton devices," *Journal of rehabilitation medicine*, vol. 44, pp. 193-199, 2012.
- [67] K. B. Kortte, L. D. Falk, R. C. Castillo, D. Johnson-Greene, and S. T. Wegener, "The Hopkins rehabilitation engagement rating scale: development and psychometric properties," *Archives of physical medicine and rehabilitation*, vol. 88, pp. 877-884, 2007.
- [68] E. J. Lenze, M. C. Munin, T. Quear, M. A. Dew, J. C. Rogers, A. E. Begley, and C. F. Reynolds III, "The Pittsburgh Rehabilitation Participation Scale: reliability and validity of a clinician-rated measure of participation in acute rehabilitation," *Archives of physical medicine and rehabilitation*, vol. 85, pp. 380-384, 2004.

- [69] D. E. Clarke, J. Y. Ko, E. A. Kuhl, R. van Reekum, R. Salvador, and R. S. Marin, "Are the available apathy measures reliable and valid? A review of the psychometric evidence," *Journal of psychosomatic research*, vol. 70, pp. 73-97, 2011.
- [70] E. J. Lenze, M. C. Munin, T. Quear, M. A. Dew, J. C. Rogers, A. E. Begley, and C. F. Reynolds, "Significance of poor patient participation in physical and occupational therapy for functional outcome and length of stay," *Archives of physical medicine and rehabilitation*, vol. 85, pp. 1599-1601, 2004.
- [71] A. Boxtel and M. Jessurun, "Amplitude and bilateral coherency of facial and jaw-elevator EMG activity as an index of effort during a two-choice serial reaction task," *Psychophysiology*, vol. 30, pp. 589-604, 1993.
- [72] S. C. Jacobs, R. Friedman, J. D. Parker, G. H. Tofler, A. H. Jimenez, J. E. Muller, H. Benson, and P. H. Stone, "Use of skin conductance changes during mental stress testing as an index of autonomic arousal in cardiovascular research," *American heart journal*, vol. 128, pp. 1170-1177, 1994.
- [73] J. L. Andreassi, *Psychophysiology: Human Behavior and Physiological Response*, 5th ed.: Psychology Press, 2006.
- [74] H. K. Naver, C. Blomstrand, and B. G. Wallin, "Reduced heart rate variability after right-sided stroke," *Stroke*, vol. 27, pp. 247-251, 1996.
- [75] J. T. Korpelainen, K. A. Sotaniemi, H. V. Huikuri, and V. V. Myllylä, "Abnormal heart rate variability as a manifestation of autonomic dysfunction in hemispheric brain infarction," *Stroke*, vol. 27, pp. 2059-2063, 1996.
- [76] A. Koenig, X. Omlin, L. Zimmerli, M. Sapa, C. Krewer, M. Bolliger, F. Müller, and R. Riener, "Psychological state estimation from physiological recordings during robot-assisted gait rehabilitation," *J Rehabil Res Dev*, vol. 48, pp. 367-385, 2011.
- [77] M. van Dooren, J. De Vries, and J. H. Janssen, "Emotional sweating across the body: Comparing 16 different skin conductance measurement locations," *Physiology & behavior*, vol. 106, pp. 298-304, 2012.
- [78] H. Abdi, "Bonferroni and Šidák corrections for multiple comparisons," in *Encyclopedia of Measurement and Statistics*, N. J. Salkind, Ed., ed Thousand Oaks, CA: SAGE, 2007.
- [79] J. Bogousslavsky, G. Vanmelle, and F. Regli, "The Lausanne Stroke Registry - Analysis of 1,000 Consecutive Patients with 1st Stroke," *Stroke*, vol. 19, pp. 1083-1092, 1988.
- [80] H. S. Jorgensen, H. Nakayama, H. O. Raaschou, and T. S. Olsen, "Recovery of Walking Function in Stroke Patients - the Copenhagen Stroke Study," *Archives of physical medicine and rehabilitation*, vol. 76, pp. 27-32, 1995.
- [81] M. Kelly-Hayes, A. Beiser, C. S. Kase, A. Scaramucci, R. B. D'Agostino, and P. A. Wolf, "The influence of gender and age on disability following ischemic stroke: the Framingham study," *Journal of Stroke and Cerebrovascular Diseases*, vol. 12, pp. 119-126, 2003.
- [82] A. Forster and J. Young, "Incidence and consequences of falls due to stroke: a systematic inquiry," *BMJ*, vol. 311, pp. 83-6, 1995.
- [83] J. E. Harris, J. J. Eng, D. S. Marigold, C. D. Tokuno, and C. L. Louis, "Relationship of balance and mobility to fall incidence in people with chronic stroke," *Physical Therapy*, vol. 85, pp. 150-158, 2005.
- [84] S. F. H. Mackintosh, K. Hill, K. J. Dodd, P. Goldie, and E. Culham, "Falls and injury prevention should be part of every stroke rehabilitation plan," *Clinical Rehabilitation*, vol. 19, pp. 441-451, 2005.
- [85] K. M. Michael, J. K. Allen, and R. F. Macko, "Reduced ambulatory activity after stroke: The role of balance, gait, and cardiovascular fitness," *Archives of physical medicine and rehabilitation*, vol. 86, pp. 1552-1556, 2005.
- [86] V. Weerdesteyn, M. de Niet, H. J. R. van Duijnhoven, and A. C. H. Geurts, "Falls in individuals with stroke," *Journal of Rehabilitation Research and Development*, vol. 45, pp. 1195-1213, 2008.

- [87] S. Pouwels, A. Lalmohamed, B. Leufkens, A. de Boer, C. Cooper, T. van Staa, and F. de Vries, "Risk of Hip/Femur Fracture After Stroke A Population-Based Case-Control Study," *Stroke*, vol. 40, pp. 3281-3285, 2009.
- [88] F. Batchelor, K. Hill, S. Mackintosh, and C. Said, "What Works in Falls Prevention After Stroke? A Systematic Review and Meta-Analysis," *Stroke*, vol. 41, pp. 1715-1722, 2010.
- [89] L. Marchal-Crespo and D. J. Reinkensmeyer, "Review of control strategies for robotic movement training after neurologic injury," *Journal of NeuroEngineering and Rehabilitation*, vol. 6, 2009.
- [90] J. von Zitzewitz, M. Bernhardt, and R. Riener, "A Novel Method for Automatic Treadmill Speed Adaptation," *Neural Systems and Rehabilitation Engineering, IEEE Transactions on*, vol. 15, pp. 401-409, 2007.
- [91] C. K. Balasubramanian, M. G. Bowden, R. R. Neptune, and S. A. Kautz, "Relationship between step length asymmetry and walking performance in subjects with chronic hemiparesis," *Archives of physical medicine and rehabilitation*, vol. 88, pp. 43-49, 2007.
- [92] J. Bogousslavsky, *Acute Stroke Treatment*: Taylor & Francis, 1997.
- [93] D. Mozaffarian, E. Benjamin, and A. Go, "Heart disease and stroke statistics-2015 update: a report from the American Heart Association," *Circulation*, 2014.
- [94] H. Kawamoto, H. Kandone, T. Sakurai, R. Ariyasu, Y. Ueno, K. Eguchi, and Y. Sankai, "Development of an assist controller with robot suit HAL for hemiplegic patients using motion data on the unaffected side," in *Engineering in Medicine and Biology Society (EMBC), 2014 36th Annual International Conference of the IEEE*, 2014, pp. 3077-3080.
- [95] A. Mokhtarian, A. Fattah, and S. K. Agrawal, "A novel passive pelvic device for assistance during locomotion," in *Robotics and Automation (ICRA), 2010 IEEE International Conference on*, 2010, pp. 2241-2246.
- [96] D. Zanotto, P. Stegall, and S. K. Agrawal, "ALEX III: A novel robotic platform with 12 DOFs for human gait training," in *Robotics and Automation (ICRA), 2013 IEEE International Conference on*, 2013, pp. 3914-3919.
- [97] D. Zanotto, P. Stegall, and S. K. Agrawal, "Adaptive assist-as-needed controller to improve gait symmetry in robot-assisted gait training," in *Robotics and Automation (ICRA), 2014 IEEE International Conference on*, 2014, pp. 724-729.
- [98] R. Riener, L. Lünenburger, I. Maier, G. Colombo, and V. Dietz, "Locomotor training in subjects with sensori-motor deficits: an overview of the robotic gait orthosis lokomat," *Journal of Healthcare Engineering*, vol. 1, pp. 197-216, 2010.
- [99] S. A. Murray, K. H. Ha, C. Hartigan, and M. Goldfarb, "An assistive control approach for a lower-limb exoskeleton to facilitate recovery of walking following stroke," *Neural Systems and Rehabilitation Engineering, IEEE Transactions on*, vol. 23, pp. 441-449, 2015.
- [100] B. E. Lawson, "Control methodologies for powered prosthetic interventions in unilateral and bilateral transfemoral amputees," Vanderbilt University, 2014.